

POTTERTON

Kingfisher²

balanced flue gas fired boilers

KINGFISHER 2 RS 40 KINGFISHER 2 RS 50B

Kingfisher 2 RS40

G.C. No. 41 607 17

G.C. No. 41 607 44 (Sealed System)

Kingfisher 2 RS50B

G.C. No. 41 607 18

G.C. No. 41 607 45 (Sealed System)

IMPORTANT

THIS APPLIANCE IS FOR USE WITH NATURAL GAS (G20) ONLY. IT MUST BE INSTALLED AND SERVICED BY A COMPETENT PERSON AS STATED IN THE GAS SAFETY (INSTALLATION AND USE) REGULATIONS 1994.

Leave these instructions adjacent to the gas meter.

- * Compact in size; designed to building modular dimensions to blend unobtrusively with other kitchen furniture.
- * Adjustable length, telescopic balanced flue terminal, to suit 9 in. to 15 in. thick walls. Optional extra kit available to increase this to 24 in. thick walls.
- * Piezo electric push button ignition for easy lighting.
- * Robust, trouble-free design, giving easy installation and servicing.
- * Highly efficient, designed especially for natural gas operation.
- * Multifunctional gas control with single control button operation, incorporating a flame safety device.
- * Can be used beneath standard height working surfaces.
- * No by-pass pipework required in the system.

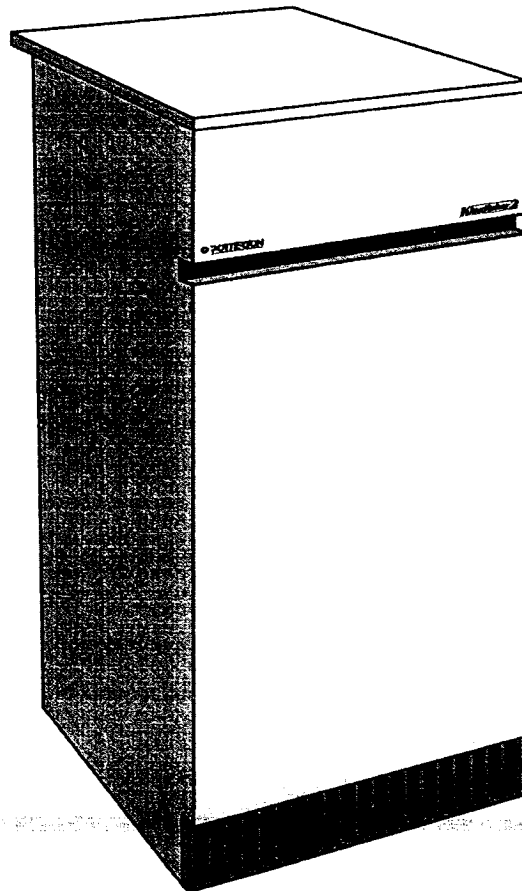

INSTALLATION AND SERVICING INSTRUCTIONS



GENERAL

These Potterton balanced flue appliances are automatically controlled and have been specially designed for combined systems, e.g. small bore or microbore central heating with an indirect domestic hot water supply which can either have pumped or gravity circulation. These boilers can also be used on a pumped central heating or domestic hot water only system.

DESCRIPTION

The boiler is finished in a white, stove enamelled, sheet steel casing, which conforms in height with other kitchen furniture. If the boiler height is required to fit flush with the top of 900mm kitchen units, then an optional extra top panel is available. An internal fitting pump kit is also available as an optional extra.

THE SYSTEM

Diagrammatic layouts of a fully pumped system and a combined pumped central heating/gravity hot water system are shown in the system diagrams. Other system variations together with their wiring arrangements are shown in the system guide leaflet.

The recommendations of BS.6798 and BS.5449 Part 1 must be observed.

When used in conjunction with the Potterton Overheat Thermostat Kit, these boilers are suitable for use in sealed systems. Full details of both installation and system requirements are available with the Kit. Under no circumstances should these boilers be connected to a sealed system if the Overheat Thermostat Kit is not fitted to the appliance.

1. All systems should be designed so that the static head at the boiler is between a minimum of 0.09 bar (3 ft.wg.) and a maximum of 3.0 bar (100.5 ft.wg.).
2. If the head is at or near the 0.09 bar (3 ft.wg.) minimum, extra care should be taken when designing the system to ensure that pumping over or ingress of air down the vent pipe cannot occur.
3. All gravity systems should have a minimum effective head of 1.2m (4 ft.) between the centre line of the boiler heat exchanger and the centre line of the domestic hot water cylinder.
4. Most types of system controls, such as two-way valves, three-way valves, diverter valves, twin pumps, zone valves and room cylinder and frost thermostats can be used in conjunction with these boilers.
5. The circulating pump should be selected with reference to Fig. 9. The resistance through the boiler heat exchanger will not exceed 20 mbar (8 in.wg.) at a flow rate of 4 gal/min.
6. The resistance through any other type of system control, such as three-way valves, should also be taken into account when selecting a pump; refer to their manufacturer's literature.
7. A drain cock(s) should be fitted at the lowest point(s) in the system, so that the whole system can be drained.
8. It is recommended that all pipework to the boiler should include union fittings at suitable points to facilitate connection of the gas and water supplies.
9. The boiler must be used on indirect hot water systems only. In a fully pumped system, the primary pipework should include a lock shield valve in the return from the cylinder.

LOCATION

Potterton Kingfisher 2 boilers are slim, space-saving appliances which must be installed against the inside face of an external wall.

Potterton Kingfisher 2 R.S. boilers may be installed in any room, although particular attention is drawn to the requirements of the current I.E.E. Wiring Regulations and, in Scotland, the electrical provisions of the Building Standards applicable in Scotland with respect to the installation of the boiler in a room containing a bath or shower.

Where a room-sealed boiler is installed in a room containing a bath or shower, any electrical switch or boiler control utilising mains electricity should be situated so that it cannot be touched by a person using the bath or shower.

BOILER BASE

A level floor, which conforms to the Local Authority and Building Regulations, should be provided. Normally, insulation beneath the boiler base tray is unnecessary as floor temperatures beneath the base tray conform to the requirements of BS.5258 Part 1. However, some composition floors which tend to soften or deform at low temperatures, may need insulating. If in doubt, consult Potterton Technical Helpline.

CLEARANCE AROUND THE BOILER

For ease of installation provide temporary access particularly to the water connections at the rear of the boiler. The appliance can then be "built in" to the minimum clearance terminal dimensions on completion of the installation.

The position selected for the boiler must give the minimum clearances for operation and servicing:-

Front clearance: 610mm (24 in.)
Side clearance: 12mm (½ in.) minimum
Top clearance: 20mm (¾ in.)

The correct minimum clearance at the back of the boiler is automatically obtained once the boiler base tray is pushed up against the wall. Fig.5 shows the boiler outline and the required clearances, together with the position for the hole to fit the flue. A clearance, necessary for the pipework, may be needed on one side, but if the pipework can be run at the back or inside of any adjacent kitchen furniture, the clearance will not be necessary.

VENTILATION

If the boiler is to be installed in a confined space such as a compartment, the space will need ventilating. Openings should be provided at the top and bottom of the compartment, each having a free area of 138cm² (21in²) for RS.40, 175cm² (27in²) for RS.50B.

Where the openings draw air direct from outside the building, the free areas can be halved. Refer to British Standard Code of Practice, BS.5376 Part 2 for further guidance. Purpose designed permanent air vents are not required in the room where the boiler is installed.

The essential details for compartment installation are given in BS 5376:2.

IMPORTANT

These appliances are certified for safety. It is therefore important that no external control devices (e.g. flue dampers, economisers etc.) be directly connected to these appliances unless covered by these installation instructions or otherwise recommended in writing.

Any direct connection of a control device not approved by Potterton could invalidate the certification and the normal appliance warranty.

FULLY PUMPED SYSTEM

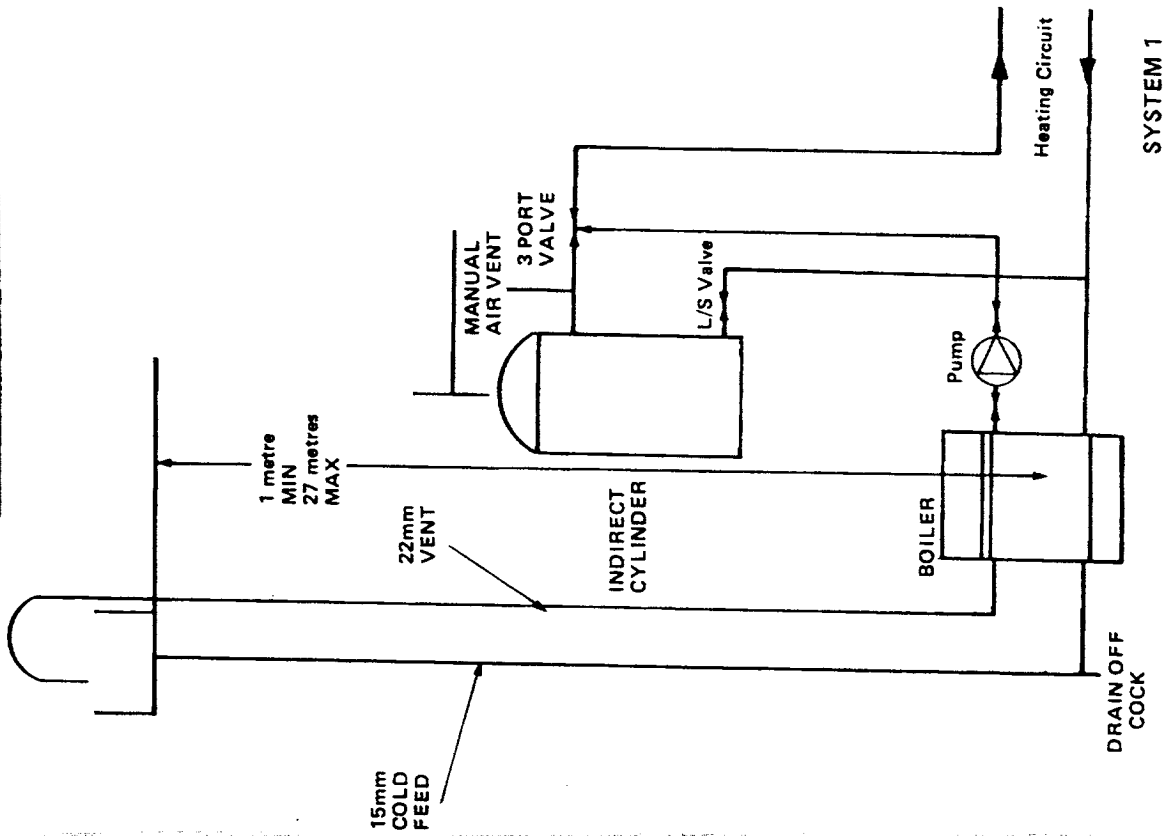

PUMPED HEATING AND GRAVITY HOT WATER

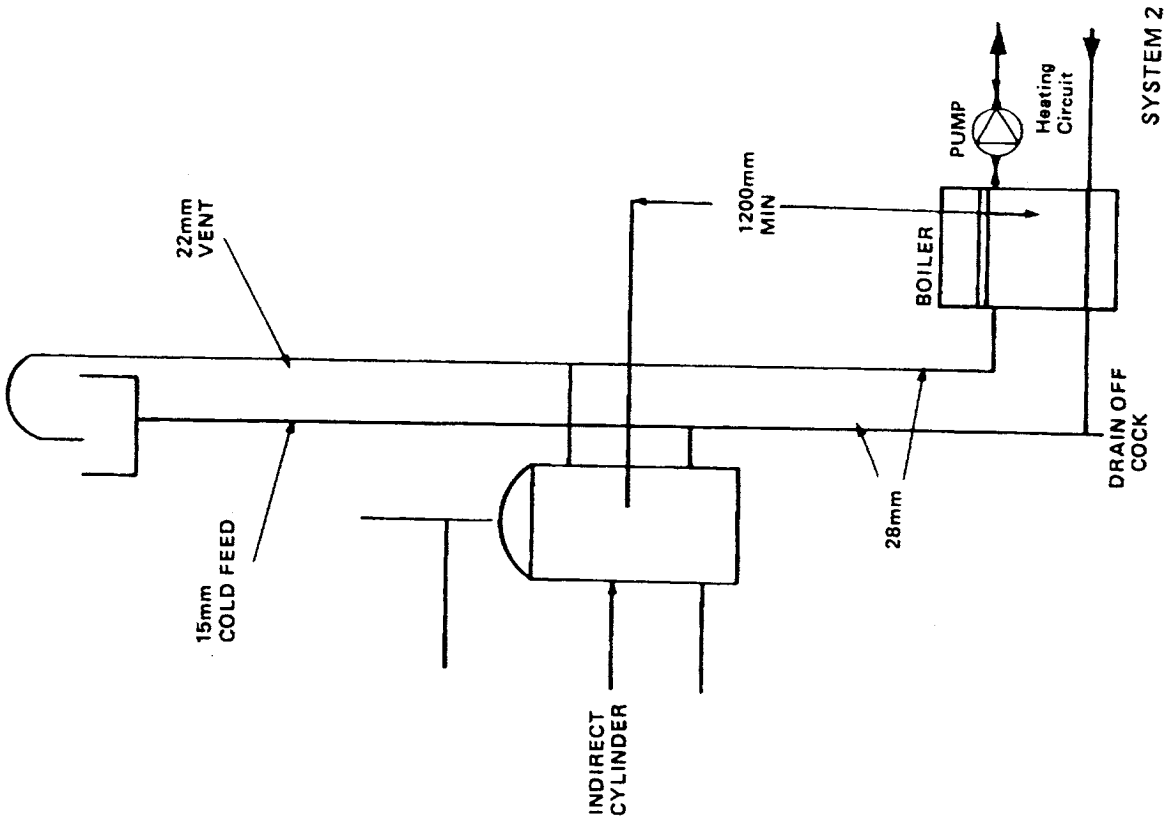

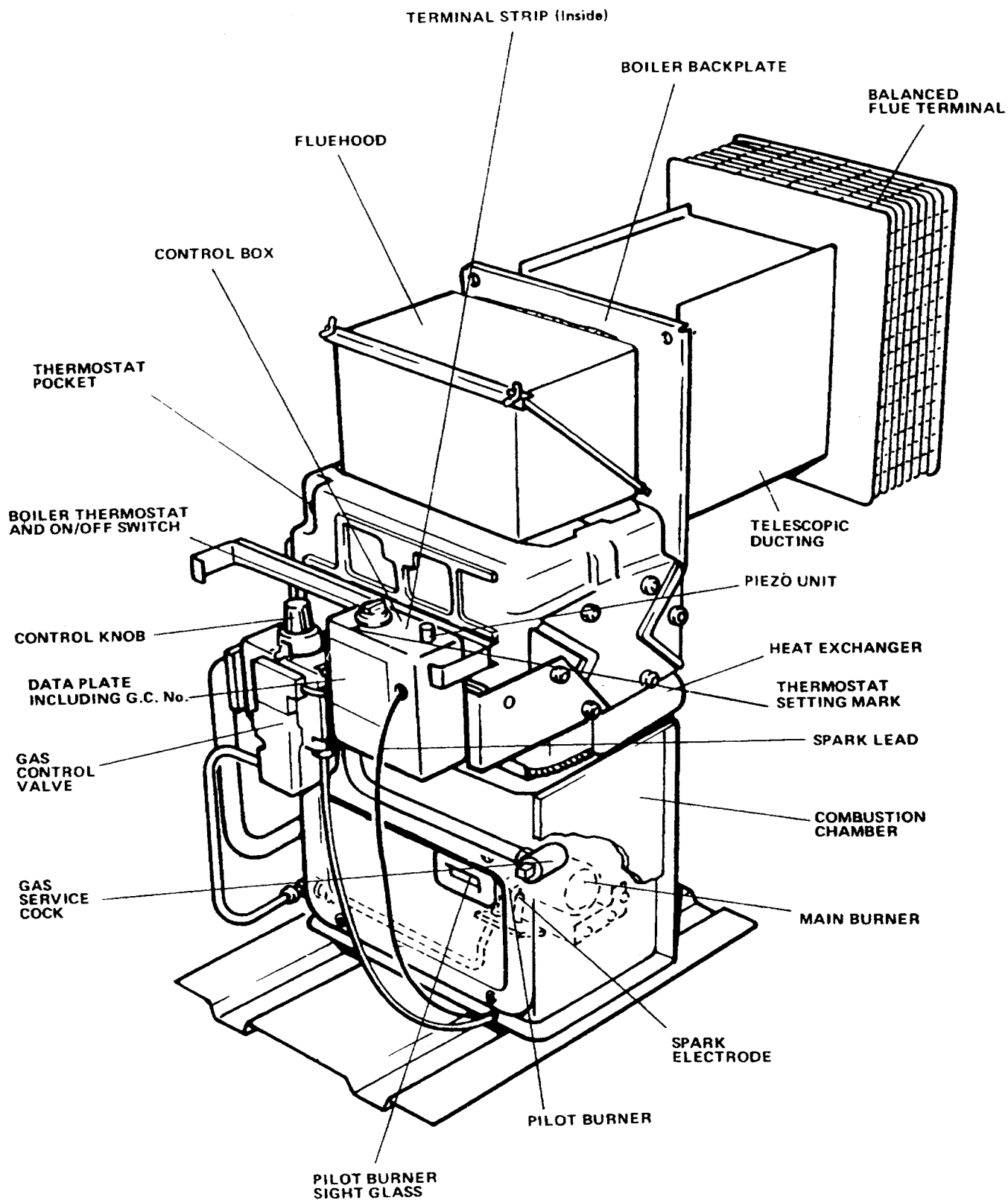

FIG. 1 GENERAL ARRANGEMENT

BALANCED FLUE TERMINAL

The correct position of the balanced flue terminal on the outside wall of the building is important. Ensure that the terminal position complies with the following data:-

TERMINAL POSITION – See Fig. 2	
a – Directly below an openable window or other opening e.g. air brick.	300 mm
b – Below gutters, soil pipes or drain pipes.	300 mm
c – Below eaves	300 mm
d – Below balconies or car port roof	600 mm
e – From vertical drain pipes and soil pipes	75 mm
f – From internal corner	600 mm
From external corners	300 mm
g – Above ground, roof or balcony level	300 mm
h – From a surface facing a terminal	600 mm
i – From a terminal facing a terminal	600 mm
j – From an opening in the car port (e.g. door, window) into dwelling	1,200 mm
k – Vertically from a terminal on the same wall	1,500 mm
l – Horizontally from a terminal on the same wall	300 mm

If the terminal discharges at a level less than 2 m (6 ft.) from the ground in an accessible position, a terminal guard, supplied as an optional extra, should be fitted.

All installations should conform with the Local Authority and Building Regulations and British Standard Code of Practice BS.5440 Part 1.

ELECTRICITY SUPPLY

A 240V ~50Hz, single phase electricity supply fused to 3A, must be provided in accordance with the latest edition of the IEE wiring regulations and any other local regulations that may apply. The current rating of the wiring to the boiler must be at least 3A in accordance with BS. 6500 Table 16, and have a cross-sectional area of at least 0.75mm² (24/0.20). High temperature cable should be used.

The method of connection to the mains electricity supply must facilitate complete isolation of the boiler together with any external controls fitted in the system, preferably by the use of a fused "three-pin" plug and shuttered socket outlet; both complying with the requirements of BS.1363. Alternatively, a fixed double pole switch, having a 3mm contact separation in both poles and serving only the boiler and external controls may be used.

The principle of wiring the boiler and external controls is shown in Fig.9.

GAS SUPPLY

The gas meter and installation pipe should be checked to ensure that they are large enough for the boiler and any other appliance already installed; the Local Gas Region will assist in this matter. The recommendations of CP.331 Parts 2 and 3 must be observed.

SAFETY VALVE AND THERMOMETER

If the local authorities regulations stipulate that a safety valve should be fitted, this should be installed in the flow pipework as close to the boiler as possible. If a thermometer is to be installed, preferably of the immersion type, this should also be fitted in the flow pipework as close to the boiler as possible.

The requirements for a sealed system are specified in the Installation Instructions supplied with the Overheat Thermostat Kit.

SERVICING

The efficient performance of this boiler is dependent upon regular servicing which should be carried out annually. Servicing is best arranged by a contract placed with Potterton Myson and further details are available from our Service Department. Servicing can be carried out once the casing front panels have been removed, all parts that are likely to require servicing are easily accessible.

COMMISSIONING

Each boiler has to be adjusted once it is installed and this is an operation which should only be undertaken by suitably qualified engineers. Potterton Myson offer this service on a chargeable basis.

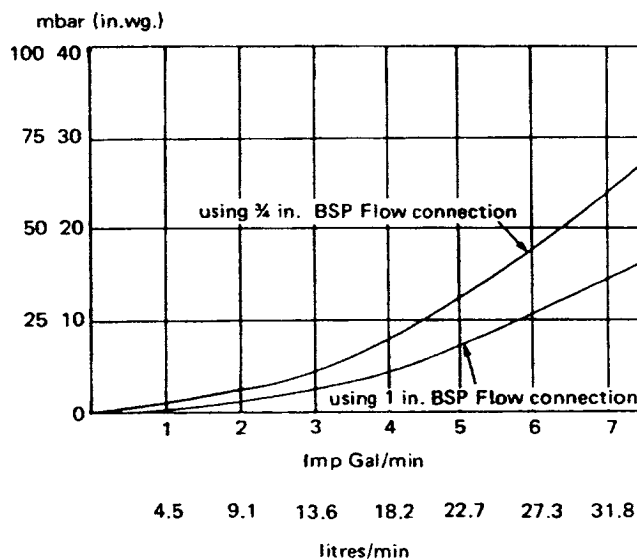

FIG. 3 PRESSURE LOSS ACROSS BOILER

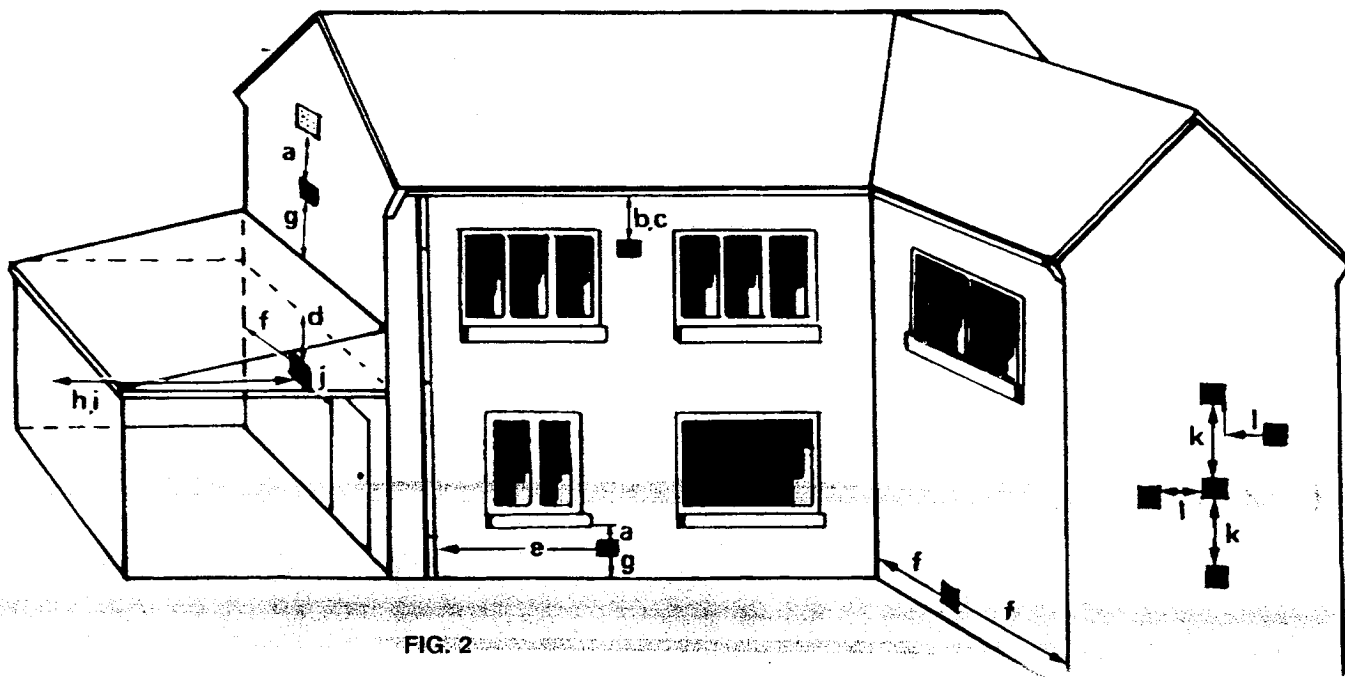

FIG. 2

ACCESSORIES

The following Potterton Myson controls are recommended for use with your boiler:

- i) Electronic Programmer- EP2001, EP3001, or EP6000
- ii) Cylinder Thermostat - PTT2 or PTT100
- iii) Room Thermostat - PRT2 or PTT100
- iv) Frost Thermostat PRT100 FR
- v) Motorised Zone Valve MSV222 or MSV228
- vi) Motorised Diverter Valve MSV322
- vii) Thermostatic Radiator Valve

Data sheets describing these products are available on request.

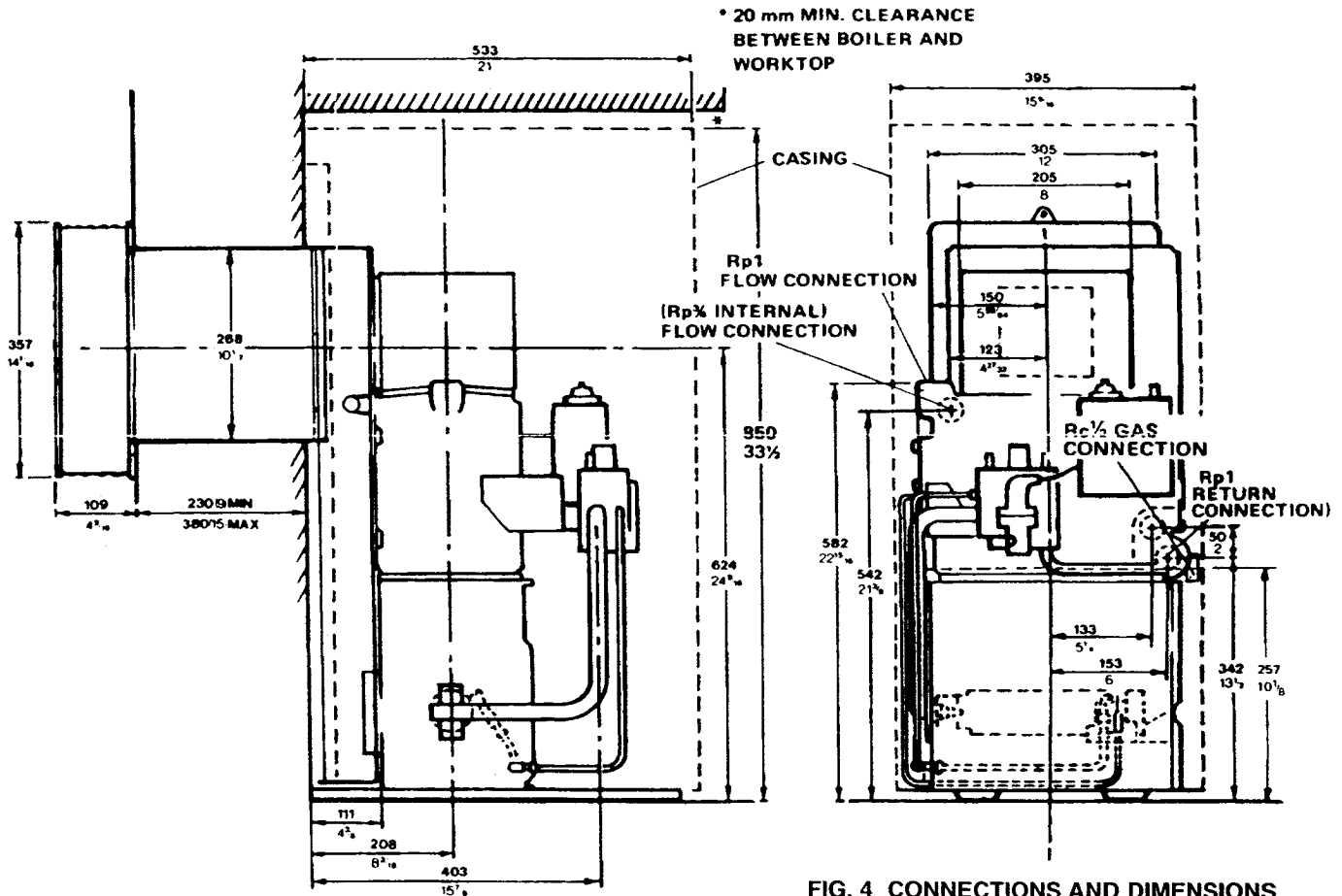

GENERAL DATA

Max. Working Head	:	3 bar (100.5 ft.wg.)
Water Content	:	5.7 litres (10 pts)
Gas Service Cock	:	Rc $\frac{1}{2}$ loose key
Gas Valve	:	S.I.T. Composit
Electrical Connection	:	To terminal strip
Thermostat	:	Ranco CL6 (flow approx. 82°C)
Burner	:	RS 40 – Furigas
	:	RS 50B – Bray
Pilot	:	RS 40 – Honeywell
	:	RS 50B – S.I.T.
Ignition	:	Vernitron Piezo Unit
Weight (empty)	:	80 Kg (176 lbs)
Dimensions	:	850mm high
	:	395mm wide
	:	533mm deep
Electricity Supply	:	240V ~50Hz
Power Consumption	:	20W (excluding pump)
Gas Supply Pressure	:	20 mbar at appliance inlet.

Performance data is based on G20 reference gas.

INSTALLATION INSTRUCTIONS

It is the law that all gas appliances are installed and serviced by competent persons as stated in Gas Safety (Installation and Use) Regulations 1994. For Health and Safety information see back page. Electrical installation and servicing should be carried out by a competent person in accordance with the I.E.E. Wiring Regulations. The Installation must be carried out in accordance with the relevant British Standard Codes of Practice and Current I.E.E. wiring recommendations. Reference should also be made to British Gas publication "British Gas specifications for Domestic Wet Central Heating Systems."

1. UNPACKING THE BOILER

A. The appliance will arrive on site in three cartons as follows:-

Carton 1

Boiler Assembly and Literature

Carton 2

Casing Pack - consisting of:-

- Case Top
- Side Panels (2)
- Case Fronts (upper and lower)
- Plinth
- Fastener Pack
- Side Infill Panel

Carton 3

Terminal Assembly and Fastener Pack

B. To avoid damage, do not open the casing pack until the boiler is positioned.

NOTE: When the Overheat Thermostat Kit is used, refer to the fitting instructions supplied with the kit.

2. CUTTING THE HOLE FOR THE BALANCED FLUE DUCTING

- Decide the most suitable position for the boiler, taking into account the information given previously, and paying particular attention to the siting of the balanced flue terminal on the outside wall of the building. See Fig. 2 & 5.
- Cut a clearance hole in the wall for the terminal ducting as neatly as possible - minimum hole size should be 275 mm (10 7/8 in.) high and 210 mm (8 1/4 in.) wide.

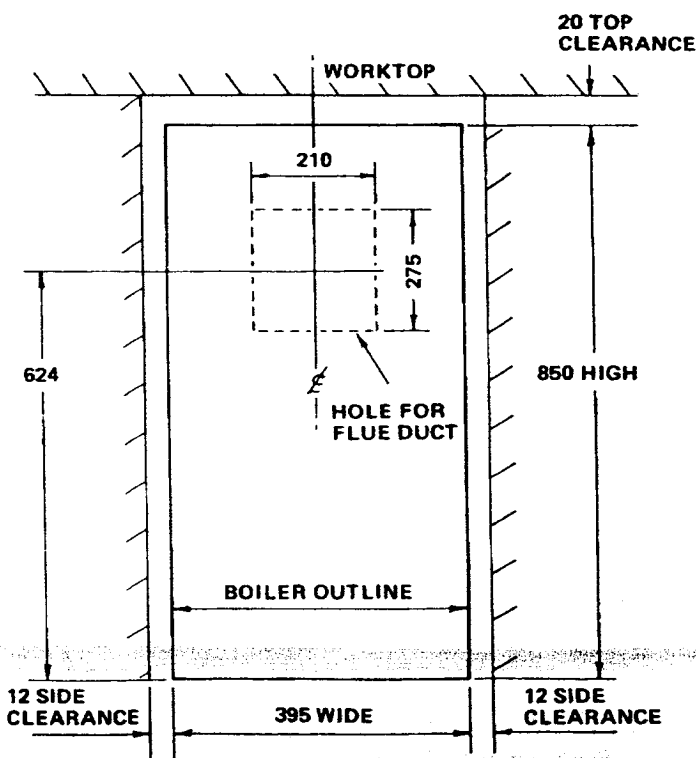

FIG. 5

3. PRE-PIPING THE WATER CONNECTIONS

General

All pre-piping should be completed prior to positioning the boiler. This enables the boiler to be installed with limited access and ensures that adequate clearance is available to fit the casing.

The return connections at the rear of the heat exchanger should be copper to iron compression type fittings. They may be either straight connectors used with formed pipework, or the lower fitting for the central heating pumped return may be a compression elbow. In this case, the elbow should be fitted prior to the straight connector. There is no room to turn a compression elbow for the Rp1 gravity return tapping.

A. Combined Gravity System - See System Diagram 2

- Connect a 145 mm length of 28 mm pipe to a 1 in. BSP to 28 mm copper to iron compression elbow on the Rp1 gravity flow tapping at the top of the heat exchanger. A 28 mm elbow can then be angled to exit the boiler at the desired position.
- Fit a 3/4 in. BSP to 22 mm copper to iron straight compression fitting to the 3/4 in. BSP M & F elbow fitted to the pumped flow tapping position at the rear left-hand side of the heat exchanger. If the Potterton Internal Pump Kit is used, follow the fitting instructions supplied with the kit.
- Connect a 1 in. BSP to 22 mm copper to iron straight or elbow compression fitting to the lower Rp1 pumped return tapping. If a straight connector is used, a 50 mm length of 22 mm pipe should be used fitted to a 22 mm copper elbow.
- Connect a 1 in. BSP to 28 mm copper to iron straight compression fitting to the upper Rp1 gravity return tapping. A 50 mm length of pipe should be used.

NOTE: The cut-out in the air duct flange gives clearance for soldered 28 mm capillary elbow on the pipe.

B. Fully Pumped System or Pumped Central Heating Only: See Diagram 1.

- Either the Rp1 or Rp3/4 flow connections may be used for the 22 mm combined flow pipework. If the Rp1 flow connection is used, the vent pipe should be connected into the flow pipe as close to the boiler as possible. Blank off the Rp3/4 flow connection at the rear of the heat exchanger. If the Rp3/4 flow connection is used, then the Rp1 connection should be separately vented. If the Potterton Internal Pump Kit is used, follow the fitting instructions supplied with the kit.
- Fit either a 1 in. BSP to 22 mm straight or elbow compression fitting to the lower combined Rp1 tapping at the rear of the heat exchanger. If a straight compression fitting is used, the 22 mm pipe should be 50 mm long.
- The upper Rp1 return tapping can either be blanked off or used to connect the cold feed.

4. FITTING THE FLUE DUCT AND THE MAIN AIR BOX - (See Figs. 6 & 7)

- Locate the flue duct in the four edge clips attached to the stub duct on the air duct. Push firmly into the clips and use the roll of tape to seal around the jointing line.
- Fit the main air box to the air duct using the six M6 screws from Fastener Pack F.

NOTE: The flanges on the main air box should be upward facing.

5. FITTING THE TELESCOPIC AIR BOX - See Fig. 6 & 7.

Measure the thickness of the wall, slide the telescopic air box into the main air box and adjust the length to the wall thickness PLUS 20mm (Dim'n 'X').

Dimension 'X' is taken from the rear edge of the telescopic air box (part A), and the rear face of the air duct (part B). Seal the ducting joint with the coloured adhesive tape, ensuring a good seal over the flanges at the top of the main air box.

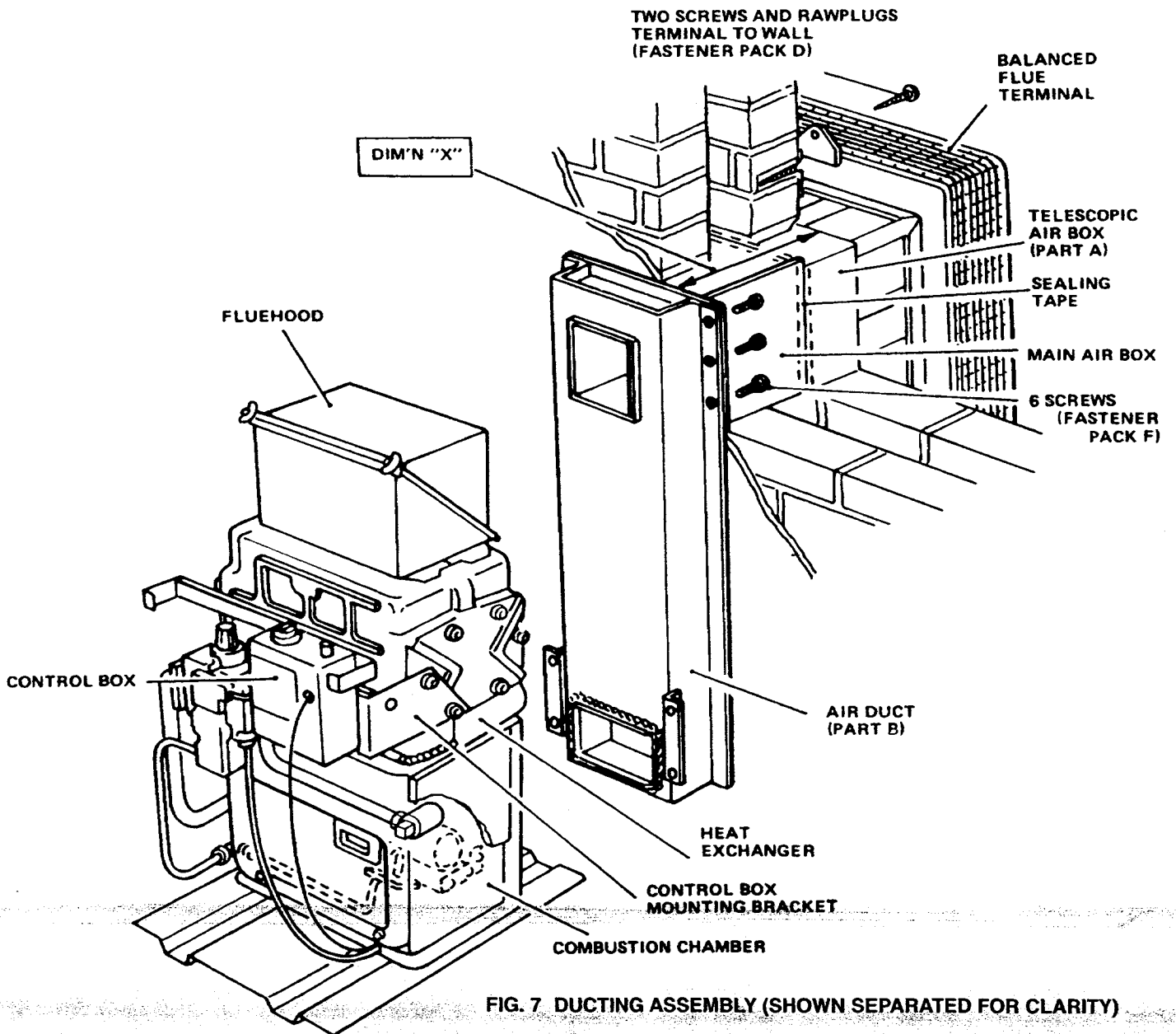
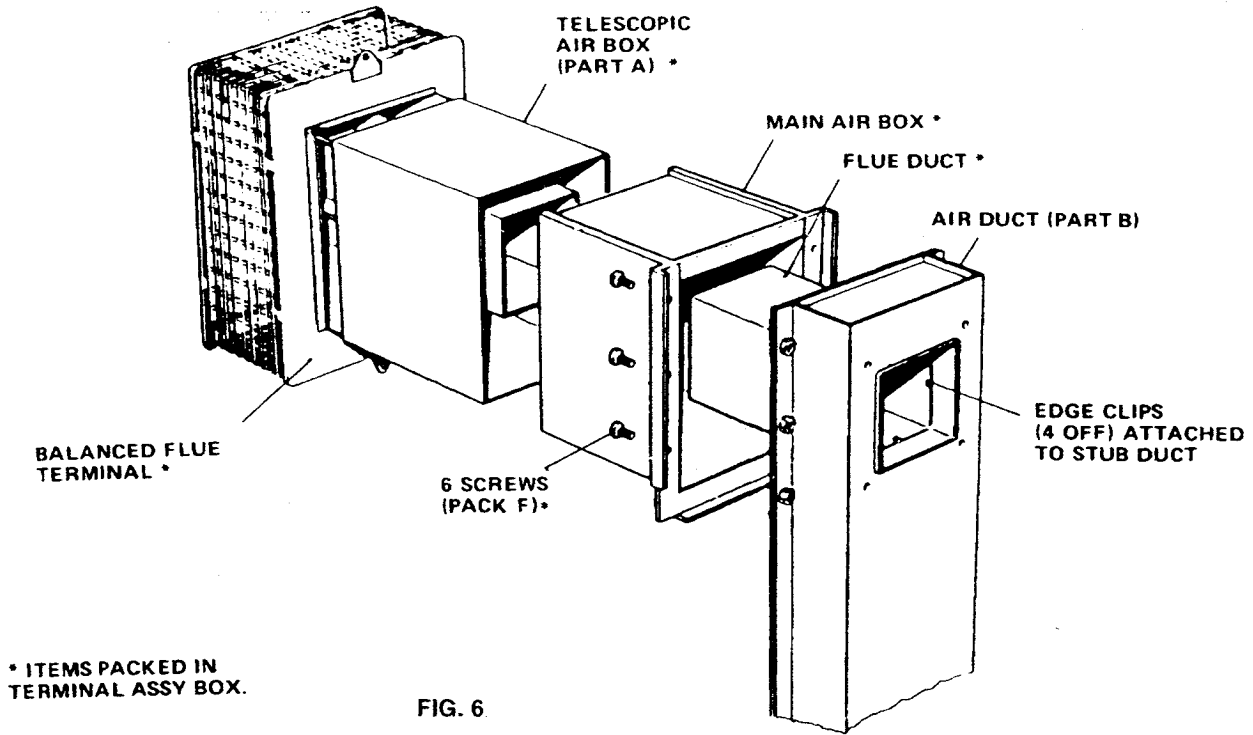

6. POSITIONING THE BOILER

NOTE: The casing top panel extends to the rear as far as the boiler base tray. Therefore, if the tray is touching the wall, the top panel will extend right up to the wall, but if the tray is positioned up against the skirting board, a gap will still remain behind the top panel, unless the skirting board is first removed.

IMPORTANT

The skirting board must be removed if the flue is set to the maximum wall thickness.

- Manoeuvre the boiler into position so that its terminal ducting enters the hole in the wall and the boiler base tray touches the wall. Before fully pushing the boiler into position, make good around the ducting.
- When the boiler has been finally positioned, check that it is level and its ducting is located squarely inside the wall.
- Working from outside the building, make good the external wall surface using a suitable sealing material.
- Engage the balanced flue terminal into the ducting retained in the wall. Ensure the two side flanges on the terminal engage inside the air box. Mark and drill the position for the wall plugs and secure the terminal to the wall.
- When applicable mark, drill and secure the terminal guard (optional extra) to the wall.

7. CONNECTIONS

- Make the flow and return connections in accordance with normal practices.
- On certain combined systems, i.e. pumped central heating and gravity hot water, it may be necessary to install a check valve to prevent gravity circulation in the heating circuit when the pump is not working. This valve must be installed with the arrow on it pointing vertically upwards and in the direction of the flow.
- If the Potterton Internal Pump Kit is not used, then the circulating pump can be fitted to either the flow or return to suit the installation.
- Connect the gas supply pipe to the boiler gas service cock. In order to coincide with the cut out in the casing side panel the pipe should be angled downwards from the service cock. See Fig.8.
- Ensure a drain cock(s) is fitted to the lowest point(s) in the system.
- Remove the circulating pump, open all water valves and thoroughly flush the system.
- Refit the pump, fill and vent the water system and test for water soundness, rectify if necessary.

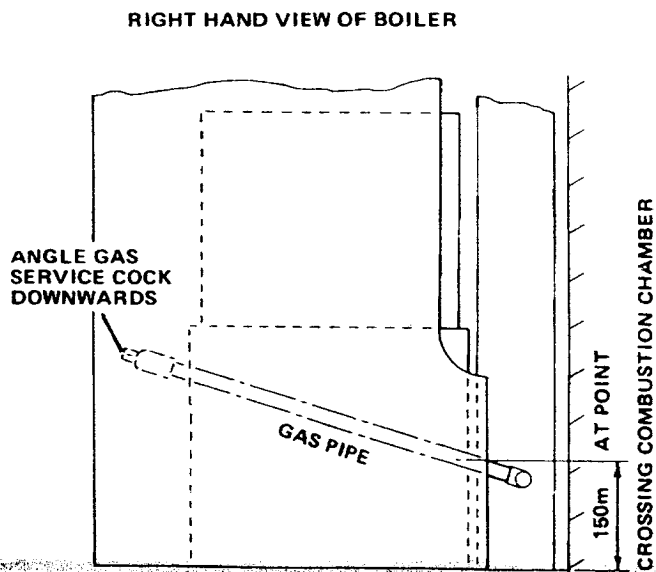

FIG. 8

8. WIRING

If the Overheat Thermostat Kit is to be used, refer to Section 3 'Wiring' in the instructions supplied with the kit for connection details. When the kit is incorporated, 4 core cable must be fitted as shown in the wiring diagram.

Care must be taken to ensure that all wiring to the boiler is kept clear of sharp edges and hot surfaces.

NOTE: Ensure that the earth conductor is longer than the L and N from the point of anchorage, so that the current carrying conductors become taut before the earth conductor.

Ensure that sufficient input cable is provided to allow routing along the top of the casing side panel. (See Section 12 - Casing).

Remove the side screw and hinge the control box from its housing to expose the terminal strip.

The boiler terminal strip is not designed to accept wiring from all the on-site system controls and therefore the installer will usually need to incorporate a suitable junction box. The principle of wiring up the boiler and its controls is shown in Fig.9. However, the layout of a particular system will itself govern the most economical location for the junction box and its terminals.

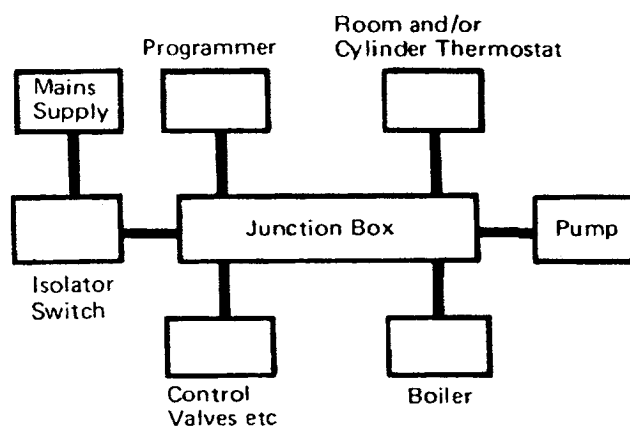

FIG. 9 PRINCIPAL OF WIRING

System wiring arrangements are shown in the system guide of the installation instructions pack.

When all wiring is complete hinge the control box into its housing and secure it with the side screw.

9 COMMISSIONING THE BOILER

BEFORE LIGHTING THE BOILER, THE WHOLE OF THE GAS INSTALLATION, INCLUDING THE METER MUST BE INSPECTED AND TESTED FOR SOUNDNESS, AND PURGED, IN ACCORDANCE WITH THE RECOMMENDATIONS OF CP.331: PART 3.

9.1. PRELIMINARY ELECTRICAL SYSTEM CHECKS

In the event of an electrical fault after installation of the appliance, preliminary electrical system checks, as described in the British Gas Multi-meter instruction book must be carried out. The checks to be carried out are:—

- Earth Continuity Check
 - Short Circuit Check
 - Polarity Check
 - Resistance to Earth Check
- See Figures 10a,10b

IMPORTANT

This series of checks are the first electrical checks to be carried out during a fault finding procedure. On completion of a service/ fault finding task which has required the breaking and remaking of electrical connections, then the checks A. Earth Continuity; C. Polarity; and D. Resistance to Earth must be repeated.

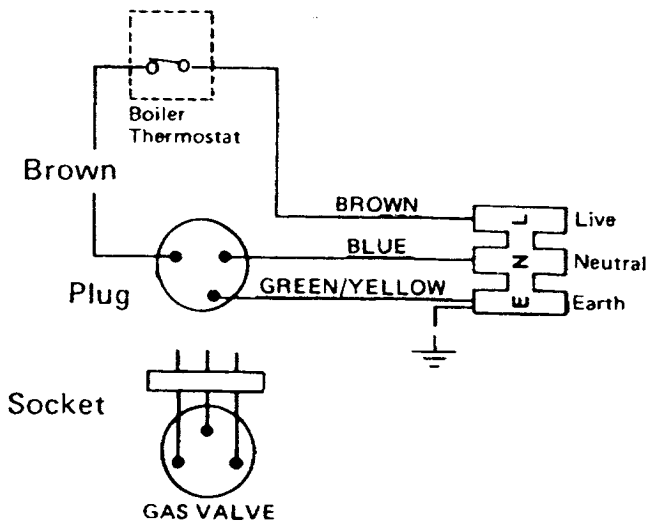

FIG. 10 a BOILER WIRING DIAGRAMS

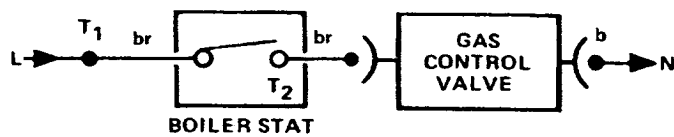

FIG. 10 b

10. FIRST LIGHTING

- Check that the main electricity supply to the boiler is switched on and that the boiler thermostat is in the OFF position.
- Turn on the gas supply.

WARNING: OPEN ALL WINDOWS AND EXTINGUISH ANY NAKED LIGHTS IN THE ROOM AND PUT OUT PIPES AND CIGARETTES.

- Break the union at the boiler gas service cock, then open the cock and purge any air from the supply pipe. See CP.331 Part 3.
- Close the cock, remake the union then re-open the cock and test for gas soundness using a soap solution.

WARNING: DO NOT USE A NAKED FLAME.

- Ensure that the system is full of water and that the pump and radiator isolating valves are open.
- Ensure that the time control, if fitted, is in an 'ON' condition, and that the room and/or cylinder thermostat, where fitted are set to high temperatures.
- Turn the control knob on the gas control valve clockwise until the black dot lines up with the mark on the gas valve body. This ensures that the valve is in the 'OFF' condition. (See knob details).

KNOB DETAILS

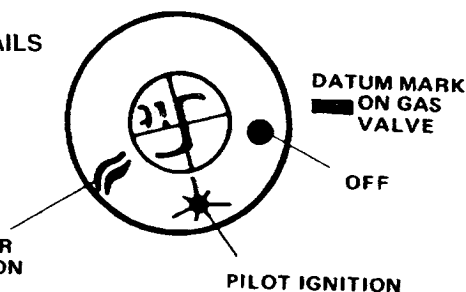

- Depress and turn the control knob on the gas valve anti-clockwise so that the stylised ignition symbol lines up with the mark on the gas valve body. Press and hold in the control knob and press the piezo unit until a click is heard. Release the piezo unit and repeat operation until the pilot ignites. Check through the sight glass that the pilot has ignited. Hold in the control knob for a further 15 seconds, on release the pilot should remain alight. Depress and turn the control knob anti-clockwise until the stylised flame symbol lines up with the mark on the valve body.

NOTE: On first lighting, establishment of the pilot flame may be slightly delayed due to the presence of air in the pipework and several operations of the piezo unit may be necessary.

If the pilot fails to light or goes out at any time, immediately turn the control knob clockwise as far as possible, then release it and wait three minutes before repeating the lighting procedure. The control knob should not be touched during this period.

- Turn the boiler thermostat to a high setting and the main burner will light.
- Set the boiler thermostat and the room and/or cylinder thermostat(s) and time control, where installed to their required operating conditions.
- Check for gas soundness of joints using leak detection fluid.
- Allow the system to reach maximum working temperature and examine for water soundness. Drain the system whilst it is still hot, then refill and vent and make a final examination for water soundness.

11. FINAL ADJUSTMENT

A. Gas rate and main burner pressure setting

- Fit a pressure gauge to the pressure test nipple at the outlet side of the gas valve (see Fig.12).
- Turn on the boiler thermostat, then check that the burner pressure is in accordance with Table 1.
- If burner adjustment is necessary, turn the small slotted head screw, located on the top of the control valve between the control knob and the inlet pressure tapping, (clockwise to decrease pressure). Shut down the boiler, remove the pressure gauge, and refit the screw in the pressure test nipple, ensuring a gas tight seal is made.
- With the burner set to its correct pressure, the heat input given in Table 1 should also be obtained and this should be checked by meter reading over a period of at least 5 minutes once the boiler is hot.
- When the desired heat input is achieved, remove the self-adhesive arrow from the inspection ticket and stick it to the Data Plate to indicate the burner setting pressure appropriate to the system design.

TABLE 1		RS 40			RS 50B		
Heat Input	kW	12.2	13.8	15.5	15.5	17.3	19.1
	Btu/h	41,500	47,250	53,000	53,000	59,000	65,000
Heat Output into Water	kW	8.8	10.3	11.7	11.7	13.2	14.7
	Btu/h	30,000	35,000	40,000	40,000	45,000	50,000
Heat Output into Air (approx)	kW	0.5	0.8	1.1	0.5	0.8	1.1
	Btu/h	1780	2730	3700	1780	2730	3700
Burner Pressure	mbar	7.2	8.6	11.3	9.1	12.0	14.5
	in. wg.	2.9	3.45	4.5	3.6	4.8	5.8
Injector Size/Marking		3.3			3.5		
Gas Rate	cu.m/h	1.14	1.32	1.45	1.45	1.63	1.78
	cu.ft/h	40.1	46.5	51.2	51.2	57.0	62.8
G.C. No.		41 607 17			41 607 18		
Potterton Code		HEL			HEM		

B. Pilot Burner

The pilot burner is factory-set for both the RS.40 and the RS.50B, and therefore no adjustment should be required. However, should the pilot adjustment screw need to be removed or altered for any reason, this may be carried out with the use of a coin.

The pilot flame should heat the thermocouple so that the pilot safety device is "held in" but must not cause the thermocouple to glow bright red. Fig.11 shows the approximate pilot sizes for each appliance. The E.M.F. generated by the thermocouple should be of the order of 20 - 30 mV open circuit, 10 - 14 mV closed circuit. Drop out should occur between 1 - 3 mV closed circuit.

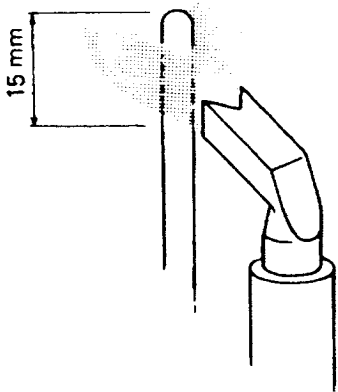

FIG. 11b PILOT FLAME RS. 40

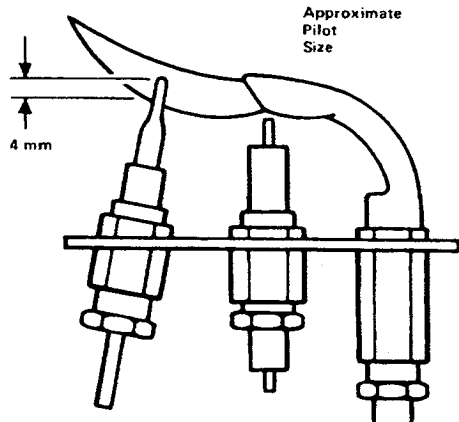

FIG. 11a PILOT FLAME RS. 50B

C. Boiler Thermostat

- 1) At its minimum and maximum settings, the thermostat should control the water flow temperature at approximately 55°C - 82°C (130°F - 180° F) respectively. This should be checked using a thermometer in the flow pipe or a "clipon" type if one is not fitted.
- 2) The thermostat has been calibrated by the makers and no attempt should be made to recalibrate it on site. Turn the thermostat to the 'OFF' position and check that the main- burner shuts down.

D. Gas Control Valve

i) Main Solenoid

Check the operation of the valve by turning off the electricity supply, either by the isolating switch or the time control, where installed. The main burner must shut down immediately.

ii) Pilot Solenoid

Turn the gas control knob to the OFF position. The pilot must shut down and a "click" indicating thermocouple drop out, should be heard within 60 sec.

E. Remote Controls

Check that any other remote control connected in the system such as time clocks and thermostats, control the boiler as required.

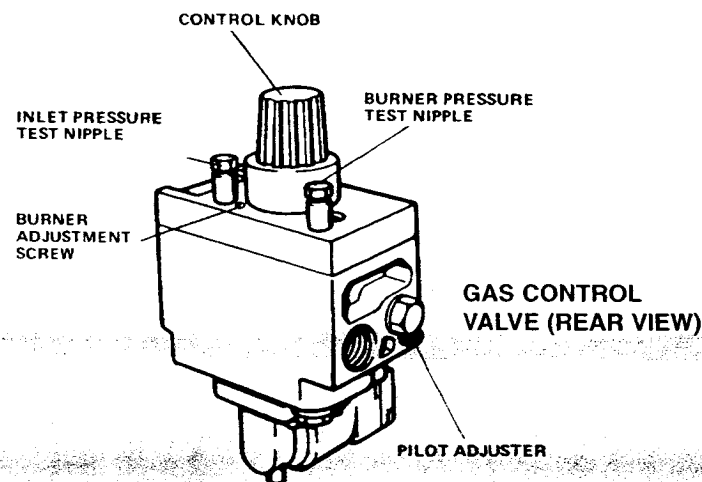

FIG. 12

12. CASING – See Fig .13

- A. Remove the casing pack contents and check against parts list
 - a) Case Top Panel
 - b) Side panels (left and right hand)
 - c) Case front panels (upper and lower)
 - d) Plinth
 - e) Fastener Pack
 - f) Side Infill Panel
- B. Electrically isolate the boiler and remove the screw at the left hand side of the control box. Hinge forward to expose the inside of the control box.
Remove the screw at the top left hand side of the control box backplate and remove the front strap from its transit position.
- C. Fit the captive nuts supplied in the Fastener Pack to the hole positions shown in Fig 13 (8 off, including 2 for the side infill panel if fitted). The 4 smaller captive nuts and screws contained in the additional bag should be fitted for the plinth.
- D. Fit the rear tie straps to the boiler backplate with the M5 screws. The cut out in the tie strap should be downward facing. (They are tied to the gas supply pipe during transit).
- E. Fit the front tie strap to the rear of the control box. Do not fully tighten the screws at this stage. (Re-use the M5 screw holding tie strap in transit position and the other from the tie strap itself).
- F. If required, the side infill panel may be fitted to the left or right hand side panel to improve the side appearance of the boiler. The side panels are handed by the location label fitted to the lower, rear corner of the side panel.
- G. Using the locating labels to identify the correct panel, fit the correct holes in the side panels over the knibs on the rear of the boiler base tray.
- H. Use self-tapping screws to secure the side panels to the rear tiestrap, front tie-strap and the captive nuts at the front of the boiler base tray
- J. Fit the cable retaining clips to the top flange on the appropriate side panel. Ensure that the cable is routed away from hot metallic surfaces.
- K. Pick up the casing top panel and locate the plastic panel fasteners over the larger diameter of the keyhole cut-outs in the side panel. Slide the top panel towards the wall to lock into position. Secure the front of the top panel with two self-tapping screws and captive nuts.
- L. Square up the casing assembly and secure in position by fully tightening the screws left loose at the rear of the control box. Close the control box and secure with the side screw. Ensure the thermostat phial is pushed fully into the pocket and securely located by its split pin.
- M. Fit the plinth to the four captive nuts at the base of the side panels using the screws and washers from the additional polythene bag. The two lugs on the plinth should be uppermost and forward facing.
- N. Fit the brass studs to the smaller hole of the bank of three holes in each side of the upper front panel using the M5 nuts and shakeproof washers. Push firmly home into the retainers in the side panels.
- P. Fit the universal case restraining brackets (two RS50B, one RS40) and their captive nuts to the holes beneath the bank of three holes in the flange of the lower front panel (See Fig.13).
Fit the brass studs to the smaller holes in the bank of three holes in each side of the lower front with the M5 nuts and shakeproof washers.
- Q. Locate the two slots on the bottom flange of the lower front panel over the locating lugs on the plinth, spring the panel restrainer inside the side panel flange and push firmly home into the retainers in the side panel.
The case assembly is now complete. It is possible to adjust the boiler thermostat, or turn the boiler off without removing the lower front panel, simply pull the panel forward and allow the restrainer to rest against the side panel.
If a second side infill panel or casing top panel extension to allow flush fitting with 900 mm kitchen units are required, they may be obtained as optional extras.
- R. Remove the temporary label from the top of the casing, having checked compliance with the information it contains.
NOTE: If the Overheat Thermostat Kit is used, stick the revised wiring diagram label over the wiring section of the information label fitted to the inside of the casing lower front panel.

13. INSTRUCT THE USER

The installer should demonstrate the operation of the boiler to the householder, and ensure that all boiler literature is handed over to the user. The installer should advise the householder on the precautions necessary to avoid damage during frost conditions. The householder should be advised that, for continued efficient and safe operation, it is important that adequate and regular servicing is carried out on the boiler.

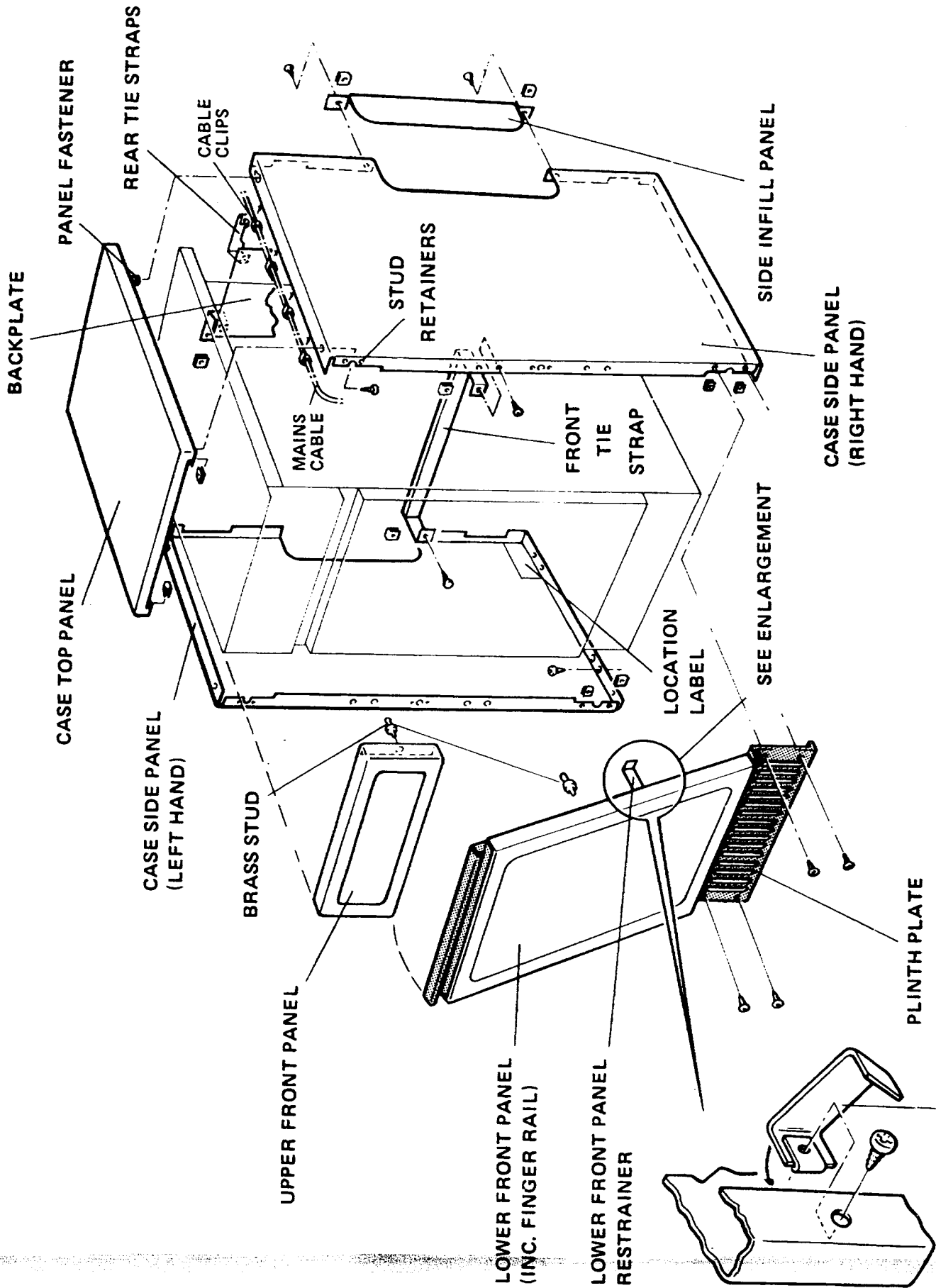

CASE RESTRAINING BRACKET
 (Fit to both left and right hand flanges, RS50B)
 (Fit to right hand flange, RS40)

FIG. 13

SERVICING INSTRUCTIONS

SERVICING INSTRUCTIONS

Regular skilled servicing and cleaning of the appliance is essential to ensure continued safe and efficient operation.

The frequency of cleaning will depend upon the particular installation conditions, and the use to which the appliance is put, but in general, once per year should be adequate.

It is the law that all gas appliances are installed and serviced by competent persons as stated in Gas Safety (Installation and Use) Regulations 1994. For Health and Safety Information see back page.

Electrical installation and servicing should be carried out by a competent person in accordance with the I.E.E. Wiring Regulations.

If there has been any delay in cleaning and the boiler has been switched off, it is desirable to operate the boiler for a short time to dry out deposits in the flueways which, if they are left in the cold state, will absorb moisture and become both corrosive and difficult to remove.

The following notes apply to the boiler and its controls, but it should be remembered that attention must also be paid to the heating circuit itself including radiator valves, thermostats, the time control and the expansion and feed water system. In all cases prior to servicing light up the boiler and check that the pilot and main burners have a clean, even flame and that the gas rate and main burner pressure is correctly set.

Before the start of any servicing work, switch off the main electricity supply and disconnect the plug at the main isolating switch and socket. Turn off the boiler gas service cock.

Where it is required to break any seal during servicing, the seal should be examined carefully for damage, and if necessary replaced. It is important to obtain the correct Potterton Myson approved part for the seal replacement which is available from Interpart spares stockists, or where difficulty in supply is experienced, through our Parts Division.

After any servicing or component replacement, always test the boiler for gas soundness and carry out functional checks of controls. (See Commissioning Section in Installation Instructions.)

1. PREPARING THE BOILER

- Remove the casing upper and lower front panels by pulling forward.
- Remove the plinth after removing the four screws and washers.

2. MAIN BURNER ASSEMBLY — REMOVAL AND CLEANING

i. RS 40 only

- Remove the combustion chamber front panel after removing the four M6 securing screws.
- Remove the brass wing nut securing the burner to the underside of the bracketry locating the pilot assembly. Ease the burner upwards then to the right and manoeuvre the burner from the combustion chamber. Remove all deposits from the burner with a soft brush.
- Do not attempt to refit the burner into the combustion chamber at this stage, as the flueways in the heat exchanger have first to be cleaned.
- Drape a suitable cloth over the pilot burner assembly so that when the heat exchanger is cleaned the deposits removed do not foul the pilot, spark electrode or thermocouple.

ii. RS 50B only

The RS 50B burner is attached to the combustion chamber front plate.

- Disconnect the union at the boiler service cock.
- Disconnect the earth lead to the gas valve socket by removing the screw.
- Remove the central screw retaining the lower section of the plastic terminal cover. Gently ease forward the top section of the plastic connector and at the same time pull it away from the tag connections.
- If an Overheat Thermostat kit is fitted, slacken the thermocouple and remove the thermocouple interruptor.
- Remove the screw and nut securing the gas control valve to its

mounting bracket and disconnect the spark lead from the piezo unit.

- Remove the combustion chamber front plate after removing the four securing screws and withdrawing the plate complete with burner assembly.
- Inspect the burner and remove any deposits from the flame strips with a soft brush.
- Do not attempt to refit the burner assembly into the combustion chamber at this stage, as the flueways in the heat exchanger have first to be cleaned.
- Drape a suitable cloth over the floor plate in the combustion chamber to catch all deposits removed from the heat exchanger during cleaning.

3. TO CLEAN HEAT EXCHANGER

- Remove the two M6 nuts and washers and remove the retaining strap, tie rods and fluehood from the top of the heat exchanger.
- Working from above and below the heat exchanger, use a suitable brush and remove all deposits from between the fins of the casting.
- Refit the fluehood, ensuring that a good seal is made with both the boiler backplate and the top of the heat exchanger. Fully tighten the two M6 nuts.
- Remove the cloth and clean out any deposits from inside the combustion chamber.

4. INJECTORS

Remove and inspect both the main burner and pilot injectors.

RS40 – Main burner injector located in supply pipe spigot at lefthand side of combustion chamber. Pilot injector located in pilot fitted to bracket at right hand side of combustion chamber,

RS50B – Both main burner and pilot injector located on burner arrangement.

The pilot injector may be removed using a blunt tool such as an Allen Key.

5. MAIN BURNER ASSEMBLY — REPLACEMENT

Re-assembly of the main burner (RS 40) or main burner gas assembly (RS 50B) is by reverse order of the removal procedure.

6. OTHER BOILER COMPONENTS

No further servicing has to be carried out on any other unit. Repair is by replacement and instructions on this are given in Section 8.

7. BOILER ADJUSTMENT

- Refit the combustion chamber front cover to the combustion chamber and secure it with four screws. Ensure an air tight seal is obtained all around the edge of the cover (RS 40 only).
- Fit a pressure gauge to the pressure test nipple at the left hand side of the control knob on the gas valve.
- Switch on the main electricity supply to the boiler and check that the boiler thermostat is in the OFF position.
- Turn on the appliance gas service cock.
- Ensure that the system is full of water and that the pump and radiator isolating valves are open.
- Ensure that the time control, if fitted, is in an ON condition, and that the room and/or cylinder thermostats, where fitted, are set to high temperatures.
- Turn the control knob on the gas control valve clockwise as far as possible and release. This ensures the valve is in the OFF condition.
- Depress and turn the control knob on the gas valve so that the stylised ignition symbol lines up with the mark on the gas valve body (See knob details). Press and hold in the control knob and press the piezo unit until a click is heard. Release the piezo unit and repeat operation until the pilot ignites. Check through the sight glass that the pilot has ignited. Hold in the control knob for a further 15 seconds on release the pilot should remain alight. Depress and turn the control knob anti-clockwise until the stylised flame symbol lines up with the mark on the valve body.

NOTE: On first lighting, establishment of the pilot flame may be slightly delayed due to the presence of air in the pipework. If the pilot fails to light or goes out at any time, immediately turn the control knob clockwise as far as possible then release it and wait three minutes before repeating the lighting procedure. The control knob should not be touched during this period.

- J. The pilot pressure is factory set and therefore should not require adjustment. However, should the pilot adjustment screw need to be removed or altered, this may be carried out with the use of a coin. The pilot flame should heat the thermocouple so that the pilot safety device is "held in" but must not cause the thermocouple to glow bright red. Fig.11 shows the approximate sizes of the pilot flames.
- K. Turn on the boiler thermostat and the main burner will light. Check that the burner pressure is in accordance with the setting indicated by the arrow fitted on the data plate.
- L. If burner pressure adjustment is necessary, turn the small slotted head screw, located on the top of the control valve between the control knob and the inlet pressure tapping, clockwise to decrease pressure or anti-clockwise to increase. Shut down the boiler, remove the pressure gauge and refit the screw in the pressure test nipple, ensuring a gas tight seal is made.
- M. Refit the casing plinth using the four screws and washers .
- N. Fit the casing upper and lower front panels by pushing into the spring clips.

8.i) RS. 40 ONLY

REMOVAL/REPLACEMENT OF BOILER COMPONENTS

A. Main Burner and Injector

- 1) Isolate the main electricity supply to the boiler and/or disconnect plug.
- 2) Carry out operations A and B under 1. 'Preparing the Boiler'.
- 3) Turn off the boiler gas service cock.
- 4) Remove the combustion chamber front panel.
- 5) Unscrew the wing nut securing the main burner to the right hand side mounting bracket inside the combustion chamber, then ease the burner upwards then to the right and manoeuvre the burner from the combustion chamber.
- 6) Remove the main burner injector from the left hand side panel of the combustion chamber.
- 7) Replacement is the reverse of removal.
- 8) Test the boiler as described in 7. 'Boiler Adjustment'.

B. Pilot Burner and Injector

- 1) Isolate the main electricity supply to the boiler and/or disconnect plug.
- 2) Carry out operations A and B under 1. 'Preparing the Boiler'.
- 3) Turn off the boiler gas service cock.
- 4) Remove the combustion chamber front panel.
- 5) Pull the tag, on the end of the spark lead off the connector on the electrode.
- 6) Remove the two screws securing the pilot assembly to its mounting bracket, then withdraw the pilot shield from the combustion chamber .
- 7) Disconnect the thermocouple lead from the pilot assembly, then withdraw the thermocouple from the combustion chamber. Ensure that the thermocouple is clean and undamaged.
- 8) Disconnect the pilot supply pipe at the base of the pilot and remove the pilot assembly. The pilot injector may drop out, but if necessary, push it out using a blunt tool such as an Allen Key.
- 9) Unscrew the back nut and remove the spark electrode from the old pilot assembly and fit it to the new one.
- 10) Replacement is the reverse of removal.
- 11) Test the boiler as described in 7. 'Boiler Adjustment'.

C. Spark Electrode

- 1) Carry out operations (1) to (9) under 'B. Pilot Burner and Injector', fitting the new electrode to the existing pilot burner assembly .
- 2) Ensure that the new electrode is correctly fitted and not bent. Check that the distance between the electrode and the hood of the pilot is between 2 mm and 4 mm.
- 3) Replacement is the reverse of removal.
- 4) Test the boiler as described in 7. 'Boiler Adjustment'.

D.i) Thermocouple (without Overheat Thermostat Kit)

- 1) Carry out operations (1) to (7) under 'B. Pilot Burner and Injector'.
- 2) Disconnect the thermocouple lead from the gas control valve, noting the route the lead takes from the pilot assembly. The replacement lead must be routed in a similar manner, so that sharp bends in the lead are eliminated.
- 3) Replacement is the reverse of removal.
- 4) Test the boiler as described in 7. 'Boiler Adjustment'.

D.ii) Thermocouple (with overheat thermostat Kit)

- 1) Carry out operations (1) to (7) under 'B. Pilot Burner and injector'.
- 2) Disconnect the thermocouple lead from the gas control valve, noting the route the lead takes from the pilot assembly. The replacement lead must be routed in a similar manner, so that sharp bends in the lead are eliminated. Care should be taken not to disturb the solenoid insert in the interrupter.
- 3) Replacement is the reverse of removal.
- 4) Test the boiler as described in 7. Boiler Adjustment.

E.i) Gas Control Valve (without Overheat Thermostat Kit)

- 1) Remove the casing front panels by pulling forward .
- 2) Turn off the gas service cock.
- 3) Isolate the main electricity supply to the boiler, and/or disconnect plug.
- 4) Disconnect the union at the boiler gas service cock.
- 5) Disconnect the pilot supply tube, thermocouple lead and thermocouple adaptor from the gas control valve.
- 6) Disconnect the earth lead to the gas valve socket and remove the screw retaining the lower section of the plastic terminal cover. Remove the plastic cover. Gently ease forward the top section of the plastic connector and at the same time pull it away from the tag connections complete with its cable.
- 7) Remove the four screws securing the gas control valve adaptor to the burner manifold. Retain the gasket for use when fitting the new valve.
- 8) Unscrew the adaptor and the inlet pipe assembly from the old valve and fit to the replacement.
- 9) Replacement is the reverse of removal.
- 10) Test the boiler as described in 7. 'Boiler Adjustment'.

E. ii) Gas Control Valve (with Overheat Thermostat Kit)

- 1) Remove the casing front panels by pulling forward .
- 2) Turn off the gas service cock.
- 3) Isolate the main electricity supply to the boiler, and/or disconnect plug.
- 4) Disconnect the union at the boiler gas service cock .
- 5) Disconnect the pilot supply tube at the gas valve .
- 6) Disconnect the thermocouple from the thermocouple interrupter and remove the soldered insert.
- 7) Remove the thermocouple interrupter from the gas valve.
- 8) Disconnect the earth lead to the gas valve socket and remove the screw retaining the lower section of the plastic terminal cover. Remove the plastic cover. Gently ease forward the top section of the plastic connector and at the same time pull it away from the tag connections complete with its cable.
- 9) Remove the four screws securing the gas control valve adaptor to the burner manifold. Retain the gasket for use when fitting the new valve.
- 10) Unscrew the adaptor and the inlet pipe assembly from the old valve and fit to the replacement .
- 11) Replacement is the reverse of removal.
- 12) Test the boiler as described in 7. 'Boiler Adjustment'.

F. i) Boiler Thermostat (without Overheat Thermostat Kit)

- 1) Remove the casing front panels by pulling forward .
- 2) Turn off the boiler gas service cock.
- 3) Isolate the main electricity supply to the boiler, and/or disconnect plug.
- 4) Remove the screw at the left hand side of the control box and hinge down to gain access.
- 5) Remove the split pin then withdraw the thermostat phial from its pocket in the heat exchanger .

- 6) Disconnect the two wires from the thermostat.
- 7) Pull off the thermostat knob, then remove the two screws and washers from around the spindle of the thermostat. Remove the thermostat complete with its capillary.
- 8) Replacement is the reverse of removal. Ensure that the new thermostat phial is inserted to the full depth of its pocket, and resecure the split pin.
The thermostat capillary should be routed away from the heat exchanger and positioned in its slot at the side of the control box. (It may be necessary to use pliers to open and close the slot).
- 9) Test the boiler as described in 7. 'Boiler Adjustment'.

F. ii) Boiler Thermostat (with Overheat Thermostat Kit)

- 1) Remove the casing front panels by pulling forward .
- 2) Turn off the boiler gas service cock.
- 3) Isolate the main electricity supply to the boiler, and/or disconnect plug.
- 4) Remove the screw at the left hand side of the control box and hinge down to gain access .
- 5) Remove the split pin from the thermostat pocket head and withdraw the boiler thermostat phial from the pocket.
- 6) Use a pair of pliers to open the thermostat capillary slot on the side of the control box and remove the capillary from the slot.
- 7) Remove the leads from the boiler thermostat, noting their positions.
- 8) Pull off the thermostat knob, then remove the two screws and washers from around the spindle of the thermostat. Remove the thermostat complete with its capillary.
- 9) Replacement is the reverse of removal. Ensure that the new phial is correctly coupled with the overheat thermostat phial and inserted to the full depth of the pocket.
The capillaries should be positioned away from the heat exchanger and sharp edges.
- 10) Test the boiler as described in 7. 'Boiler Adjustment' .

G. Piezo Unit

- 1) Remove the casing front panels by pulling forward .
- 2) Turn off the boiler gas service cock.
- 3) Isolate the main electricity supply to the boiler, and/or disconnect plug.
- 4) Pull off the lead to the piezo unit.
- 5) Remove the side screw and hinge down control box.
- 6) Unscrew the two securing screws and remove the piezo unit from the control box.
- 7) Replacement is the reverse of removal.
- 8) Test the boiler as described in 7. 'Boiler Adjustment'.

H. Spark Lead

- 1) Carry out operations (1) to (5) under B. 'Pilot Burner and Injector'.
- 2) Pull off the lead at the piezo unit.
- 3) Replacement is the reverse of removal.

CAUTION: When fitting the replacement lead, ensure that the end with the clear insulation is connected to the electrode, and that with the black insulation is connected to the piezo unit.

- 4) Test the boiler as described in 7. 'Boiler Adjustment'.

J. Overheat Thermostat (if fitted)

- 1) Remove the casing front panels by pulling forward .
- 2) Turn off the boiler gas service cock.
- 3) Isolate the main electricity supply to the boiler, and/or disconnect plug.
- 4) Remove the screw at the left hand side of the control box and hinge down to gain access .
- 5) Remove the split pin from the thermostat pocket head and withdraw the phial assemblies. Remove the coiled overheat phial from the assembly.
- 6) Use a pair of pliers to open the thermostat capillary slot in the side of the control box and remove the capillary from the slot.
- 7) Remove the two leads from the overheat thermostat .
- 8) Remove the thermostat fixing nut and remove the thermostat complete with its capillary.

- 9) Replacement is the reverse of removal. Smear the surface of the coiled end of the overheat thermostat with the heat conductive paste (available on request Part No.705086).
Ensure that the thermostat phials are correctly coupled prior to fitting into the thermostat pocket and inserted to the full depth of the pocket .
The capillaries should be positioned away from the heat exchanger and sharp edges.
- 10) Test the boiler as described in 7. 'Boiler Adjustment'.

8. ii) RS 50B ONLY

REMOVAL/REPLACEMENT OF BOILER COMPONENTS

A. Main Burner and Injector

- 1) Isolate the main electricity supply to the boiler, and/or disconnect plug.
- 2) Carry out operations A and B under 1. 'Preparing the Boiler'.
- 3) Turn off the boiler gas service cock.
- 4) Carry out operations A - F under 2ii) 'Main Burner Assembly - Removal and Cleaning'.
- 5) Remove the thermocouple and pilot tube from both the gas valve and the pilot assembly. The pilot injector will be withdrawn with the pilot tube.
- 6) Remove the spark lead from the tag at the end of the spark electrode.
- 7) Remove the pilot securing screws and transfer the pilot assembly to the new burner.
- 8) Hold the burner supply pipe and unscrew the valve complete with its inlet pipework from the assembly.
- 9) Remove the three M6 fixing screws securing the combustion chamber front plate to the burner mounting plate. The burner and its supply pipe can be withdrawn from the combustion chamber front plate.
- 10) The main burner injector may be removed at this stage.
- 11) Replacement is the reverse of removal.
- 12) Test the boiler as described in 7. 'Boiler Adjustment' .

B. Pilot Burner and Injector

- 1) Isolate the main electricity supply to the boiler, and/or disconnect plug.
- 2) Carry out operations A and B under 1. Preparing the Boiler'.
- 3) Turn off the boiler gas service cock.
- 4) Carry out operations A to F under 2ii) 'Main Burner Assembly — Removal and Cleaning'.
- 5) Disconnect the thermocouple, spark electrode and pilot supply tube from the pilot assembly. The pilot injector will be withdrawn with the supply tube.
- 6) Remove the two screws securing the pilot and shield to the burner, and refit the shield to the burner together with the new pilot. Check for gas soundness (see next section).
- 7) Replacement is the reverse of removal.

NOTE: Ensure that the thermocouple is clean and undamaged.

- 8) Test the boiler as described in 7. 'Boiler Adjustment'.

To Check Pilot Supply for Gas Soundness

This operation should be carried out externally to the boiler.

- 1) Support the burner as shown in Fig.14, and tighten the union at the gas service cock.
- 2) Turn on the gas at the service cock and turn the control knob to the pilot ignition symbol.
- 3) Hold in the control knob and at the same time apply leak detection fluid to the pilot supply connection. Rectify if necessary.
- 4) When satisfactory replace the burner assembly into the boiler. (See B. 'Pilot Burner and Injector').

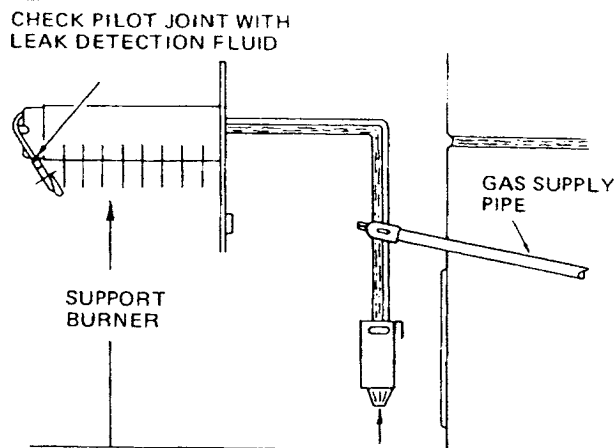

FIG. 14 LEFT HAND VIEW OF BURNER (Case Removed)

C. Spark Electrode

- 1) Remove the casing front panels by pulling forward .
- 2) Turn off the boiler gas service cock.
- 3) Isolate the main electricity supply to the boiler, and/or disconnect plug.
- 4) Carry out operations A to F under 2ii) 'Main Burner Assembly – Removal and Cleaning'.
- 5) Disconnect the spark lead from the pilot.
- 6) Unscrew the nut securing the spark electrode and withdraw electrode from the pilot assembly, Improved access can be gained if the thermocouple is removed.
- 7) Replacement is the reverse of removal.
Check the dimension between the electrode and the pilot hood is between 2 mm and 4 mm,
- 8) Test the boiler as described in 7. 'Boiler Adjustment' .

D. i) Thermocouple (without Overheat Thermostat Kit)

- 1) Remove the casing front panels by pulling forward.
- 2) Turn off the gas service cock.
- 3) Isolate the main electricity supply to the boiler, and/or disconnect plug.
- 4) Carry out operations A to F under 2ii) 'Main Burner Assembly – Removal and Cleaning'.
- 5) Disconnect the thermocouple from the gas valve and the pilot assembly, noting thermocouple route.
- 6) Remove the split grommet from the combustion chamber front panel and withdraw the thermocouple through the panel hole.
- 7) Replacement is the reverse of removal.
Ensure the new thermocouple is routed in a similar manner as the faulty thermocouple to avoid sharp bends, and that the grommet is sealed.
- 8) Test the boiler as described in 7. 'Boiler Adjustment'.

D.ii) Thermocouple (with Overheat Thermostat Kit)

- 1) Remove the casing front panels by pulling forward.
- 2) Turn off the gas service cock.
- 3) Isolate the main electricity supply to the boiler, and/or disconnect plug.
- 4) Carry out operations A to F under 2ii) Main Burner Assembly – Removal and Cleaning'.
- 5) Disconnect the thermocouple from the gas valve and the pilot assembly, noting thermocouple route. Care should be taken not to disturb the soldered insert in the interrupter.
- 6) Remove the split grommet from the combustion chamber front panel and withdraw the thermocouple through the panel hole.
- 7) Replacement is the reverse of removal.
Ensure the new thermocouple is routed in a similar manner as the faulty thermocouple to avoid sharp bends, and that the grommet is sealed.
- 8) Test the boiler as described in 7. 'Boiler Adjustment'.

E. i) Gas Control Valve (without Overheat Thermostat Kit)

- 1) Remove the casing front panels by pulling forward,
- 2) Turn off the gas service cock.
- 3) Isolate the main electricity supply to the boiler, and/or disconnect plug.
- 4) Carry out operations A to F under 2ii) 'Main Burner Assembly – Removal and Cleaning'.
- 5) Remove, the thermocouple and pilot tube from the gas valve.
- 6) Hold the burner supply pipe and unscrew the valve together with its inlet pipework from the supply pipe.
- 7) Remove the inlet pipework and refit to the new gas valve.
- 8) Screw the valve and inlet pipework assembly onto the burner supply pipe.
- 9) Remake the pilot and thermocouple connections.
- 10) Replacement is the reverse of removal.
- 11) Test the boiler as described in 7. 'Boiler Adjustment'.

E.ii) Gas Control Valve (with Overheat Thermostat Kit)

- 1) Remove the casing front panels by pulling forward.
- 2) Turn off the gas service cock.
- 3) Isolate the main electricity supply to the boiler, and/or disconnect plug.
- 4) Carry out operations A to F under 2ii) 'Main Burner Assembly – Removal and Cleaning'.
- 5) Disconnect the pilot supply tube at the gas valve .
- 6) Disconnect the thermocouple from the thermocouple interrupter and remove the soldered insert .
- 7) Remove the thermocouple interrupter from the gas valve.
- 8) Hold the burner supply pipe and unscrew the valve together with its inlet pipework from the supply pipe.
- 9) Remove the inlet pipework and refit to the new gas valve.
- 10) Screw the valve and inlet pipework assembly onto the burner supply pipe.
- 11) Remake the pilot and thermocouple connections.
- 12) Replacement is the reverse of removal.
- 13) Test the boiler as described in 7. 'Boiler Adjustment'.

F. i) Boiler Thermostat (without Overheat Thermostat Kit)

- 1) Remove the casing front panels by pulling forward.
- 2) Turn off the boiler gas service cock.
- 3) Isolate the main electricity supply to the boiler, and/or disconnect plug.
- 4) Remove the screw at the left hand side of the control box and hinge down to gain access.
- 5) Remove the split pin then withdraw the thermostat phial from its pocket in the heat exchanger .
- 6) Disconnect the two wires from the thermostat .
- 7) Pull off the thermostat knob, then remove the two screws and washers from around the spindle of the thermostat. Remove the thermostat complete with its capillary.
- 8) Replacement is the reverse of removal. Ensure that the new thermostat phial is inserted to the full depth of its pocket and secure the split pin.
The thermostat capillary should be routed away from the heat exchanger and positioned in its slot at the side of the control box. (It may be necessary to use pliers to open and close the slot).
- 9) Test the boiler as described in 7. 'Boiler Adjustment'.

F. ii) Boiler Thermostat (with Overheat Thermostat Kit)

- 1) Remove the casing front panels by pulling forward .
- 2) Turn off the boiler gas service cock.
- 3) Isolate the main electricity supply to the boiler, and/or disconnect plug.
- 4) Remove the screw at the left hand side of the control box and hinge down to gain access.
- 5) Remove the split pin from the thermostat pocket head and withdraw the boiler thermostat phial from the pocket.
- 6) Use a pair of pliers to open the thermostat capillary slot on the side of the control box and remove the capillary from the slot.
- 7) Remove the leads from the boiler thermostat, noting their positions.
- 8) Pull off the thermostat knob, then remove the two screws and washers from around the spindle of the thermostat. Remove the thermostat complete with its capillary.

- 9) Replacement is the reverse of removal. Ensure that the new phial is correctly coupled with the overheat thermostat phial and inserted to the full depth of the pocket.
The capillaries should be positioned away from the heat exchanger and sharp edges.
- 10) Test the boiler as described in 7. 'Boiler Adjustment'.

G. Piezo Unit

- 1) Remove the casing front panels by pulling forward .
- 2) Turn off the boiler gas service cock.
- 3) Isolate the main electricity supply to the boiler, and/or disconnect plug.
- 4) Pull off the lead to the piezo unit.
- 5) Remove the side screw and hinge down control box.
- 6) Unscrew the two securing screws and remove the piezo unit from the control box.
- 7) Replacement is the reverse of removal.
- 8) Test the boiler as described in 7. 'Boiler Adjustment'.

H. Spark Lead

- 1) Remove the casing front panels by pulling forward .
- 2) Turn off the boiler gas service cock.
- 3) Isolate the main electricity supply to the boiler and/or disconnect plug.
- 4) Carry out operations A to F under 2ii) 'Main Burner Assembly – Removal and Cleaning'.
- 5) Disconnect the spark lead from the pilot.
- 6) Withdraw the spark lead from the front panel sealing grommet.
- 7) Replacement is the reverse of removal.
Ensure satisfactory seal is achieved at the front panel sealing grommet.
- NOTE:** When fitting the replacement lead ensure that the black insulated end is fitted to the piezo unit.
- 8) Test the boiler as described in 7. 'Boiler Adjustment'.

J. Overheat Thermostat (if fitted)

- 1) Remove the casing front panels by pulling forward .
- 2) Turn off the boiler gas service cock.
- 3) Isolate the main electricity supply to the boiler, and/or disconnect plug.
- 4) Remove the screw at the left hand side of the control box and hinge down to gain access.
- 5) Remove the split pin from the thermostat pocket head and withdraw the phial assemblies. Remove the coiled overheat phial from the assembly.
- 6) Use a pair of pliers to open the thermostat capillary slot in the side of the control box and remove the capillary from the slot.
- 7) Remove the two leads from the overheat thermostat .
- 8) Remove the thermostat fixing nut and remove the thermostat complete with its capillary.
- 9) Replacement is the reverse of removal. Smear the surface of the coiled end of the overheat thermostat with heat conductive paste (available on request, Part No.705086).
Ensure that the thermostat phials are correctly coupled prior to fitting into the thermostat pocket and inserted to the full depth of the pocket. The capillaries should be positioned away from the heat exchanger and sharp edges.
- 10) Test the boiler as described in 7. 'Boiler Adjustment'.

9. FLAME SUPERVISION TESTING

With the boiler running, temporarily loosen the thermocouple connection at the gas valve. The main burner should shut off within approximately one second. Tighten the thermocouple connection and re-light the pilot.

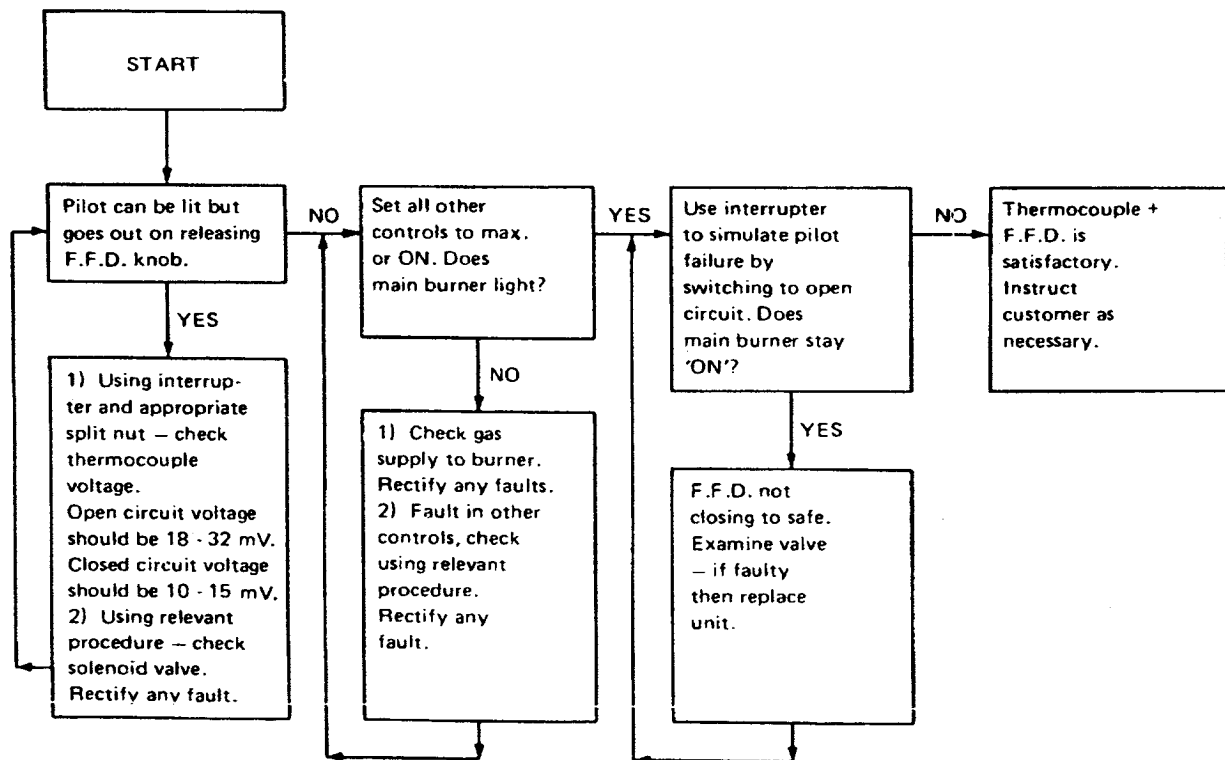

FIG. 15 F.F.D. AND THERMOCOUPLE

10. As well as the fault finding chart given, reference should also be made to the wiring diagram, Fig. 10.

CONDITION	POSSIBLE CAUSE	REMEDY
A. Pilot fails to light	<p>(1) No gas supply</p> <p>(2) Control knob not pressed fully down</p> <p>(3) Blocked pilot filter</p> <p>(4) Blocked pilot injector</p> <p>(5) Piezo unit not working</p> <p>(6) Electrode or lead damaged</p> <p>(7) Overheat Thermostat not operating</p>	<p>Check all cocks are open in the supply to the boiler</p> <p>Control knob must be pressed fully down.</p> <p>Remove the large hexagon headed plug adjacent to the inlet connection to the valve. Lift out the filter and replace as necessary.</p> <p>Remove and clean the injector as described in Section 8.</p> <p>Check that the striker and plunger mechanism is operating correctly. If the operating mechanism is correct, proceed as follows:— Disconnect the spark lead from the piezo, then place the stripped end of a suitable piece of insulated wire in the piezo, hold the other end of the wire close to the boiler waterway, then operate the piezo and check if a spark is made. If no spark appears, replace the piezo unit. If a spark is made but it does not spark at electrode:—</p> <p>Replace electrode or lead as detailed in Section 8.C or 8.H.</p> <p>(a) Check that reset button is pressed.</p> <p>(b) Check overheat thermostat using procedure given in Fig.18. Replace if necessary as detailed in 8i) or 8ii) Section J.</p>
B. Main burner fails to light and pilot is extinguished when pressure on the control knob is released	<p>(1) Control knob not held down long enough</p> <p>(2) Loose thermocouple connection into control valve.</p> <p>(3) Partially blocked pilot filter or pilot injector.</p> <p>(4) Failure of thermocouple, power unit or latching mechanism</p>	<p>Control button must be fully pressed down for 20 seconds before main valve can be energised.</p> <p>Tighten thermocouple union nut finger tight plus ¼ turn only. Ensure connection is clean and dry. TOO MUCH PRESSURE MAY DAMAGE INSULATION AND CAUSE FAILURE.</p> <p>As item A(3) and A(4).</p> <p>After pilot has been on for 20 seconds, release control knob. If pilot goes out:—</p> <p>(a) Change thermocouple, see Section 8.D and try to light pilot, if still failed then:— Power unit or latching mechanism has failed therefore:—</p> <p>(b) Change control valve, see Section 8.E. (See Fig.15 F.F.D. and Thermocouple).</p>
C. Main burner fails to light, pilot burning	<p>(1) Check that boiler controls are calling for heat</p> <p>(2) Additional controls not calling for heat</p> <p>(3) S.I.T. Control solenoid valve failed</p>	<p>Note reading of thermostat dial and check temperature of flow pipe.</p> <p>Check programmer or clock is ON and that room thermostat or other distant control is not closed down. When electrical controls are used, check for current failure.</p> <p>Check for electrical supply at control valve terminals. If no supply, check contacts on programmer or clock. Check fuses. If correct then:— Solenoid valve has failed, replace as described. (See Fig.16 Solenoid Valve)</p> <p>(a) Disconnect electrical supply to the valve as described under 8.E.</p> <p>(b) Remove solenoid valve by unscrewing the two screws securing the solenoid valve to the base of the control valve.</p> <p>(c) Lift off the solenoid valve and its gasket.</p> <p>(d) Re-assemble in reverse order.</p>
D. Burner fails to shut down when water reaches pre-determined temperature.	(1) Thermostat out of calibration or faulty	Remedy as in item C.(4)
E. Burner fails to light when water temperature is too low with controls calling for heat	(1) Thermostat out of calibration or faulty	Remedy as in item C.(4)

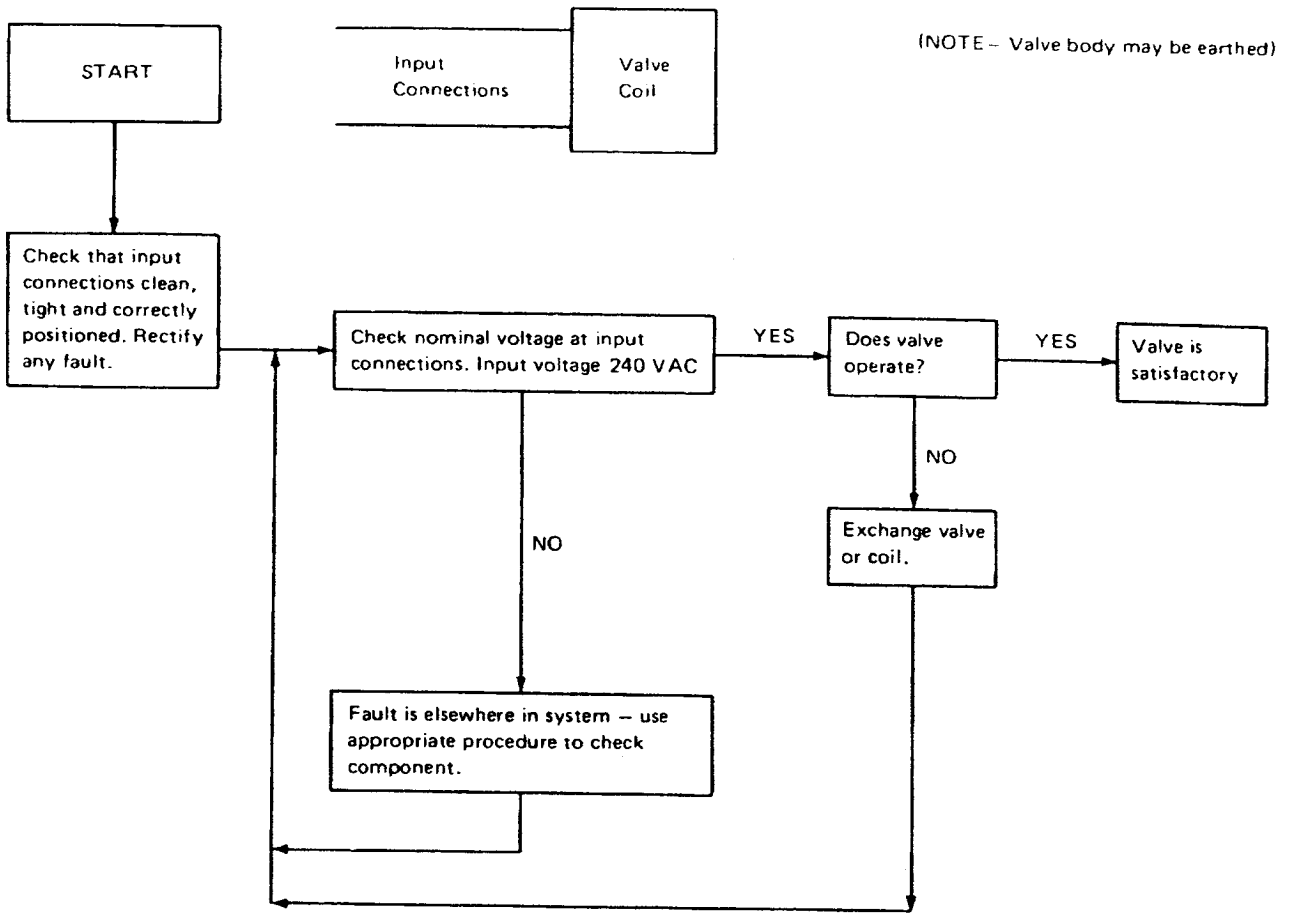

FIG. 16 SOLENOID VALVE

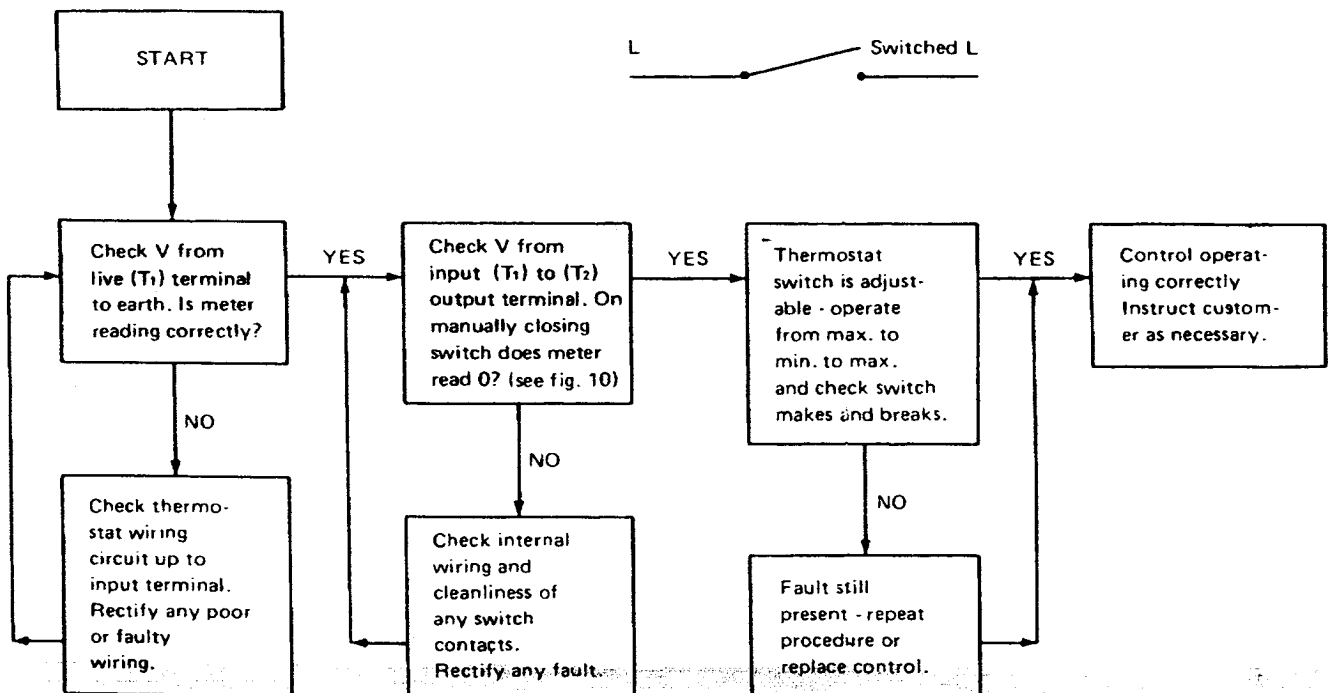

FIG. 17 THERMOSTAT

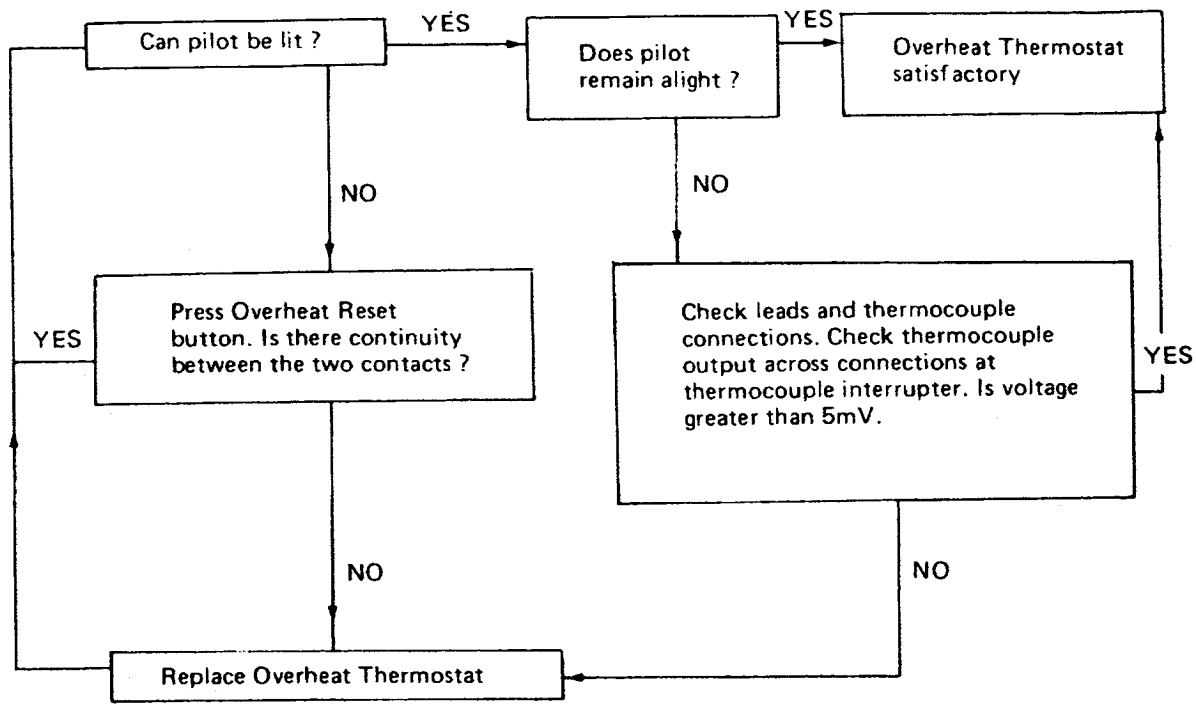

FIG. 18 FAULT FINDING OVERHEAT THERMOSTAT

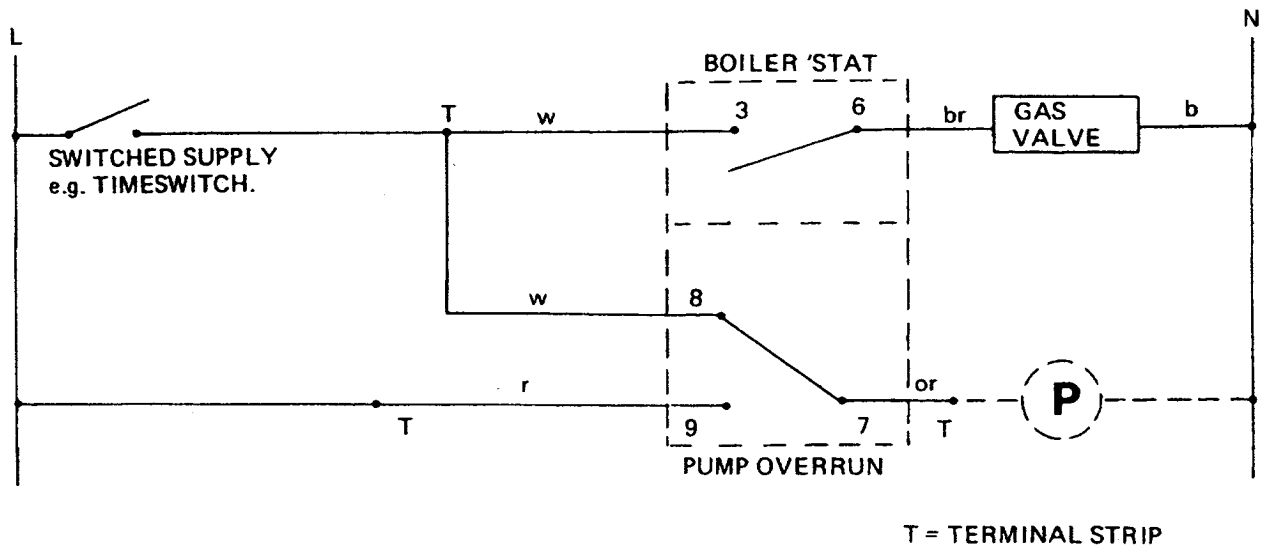
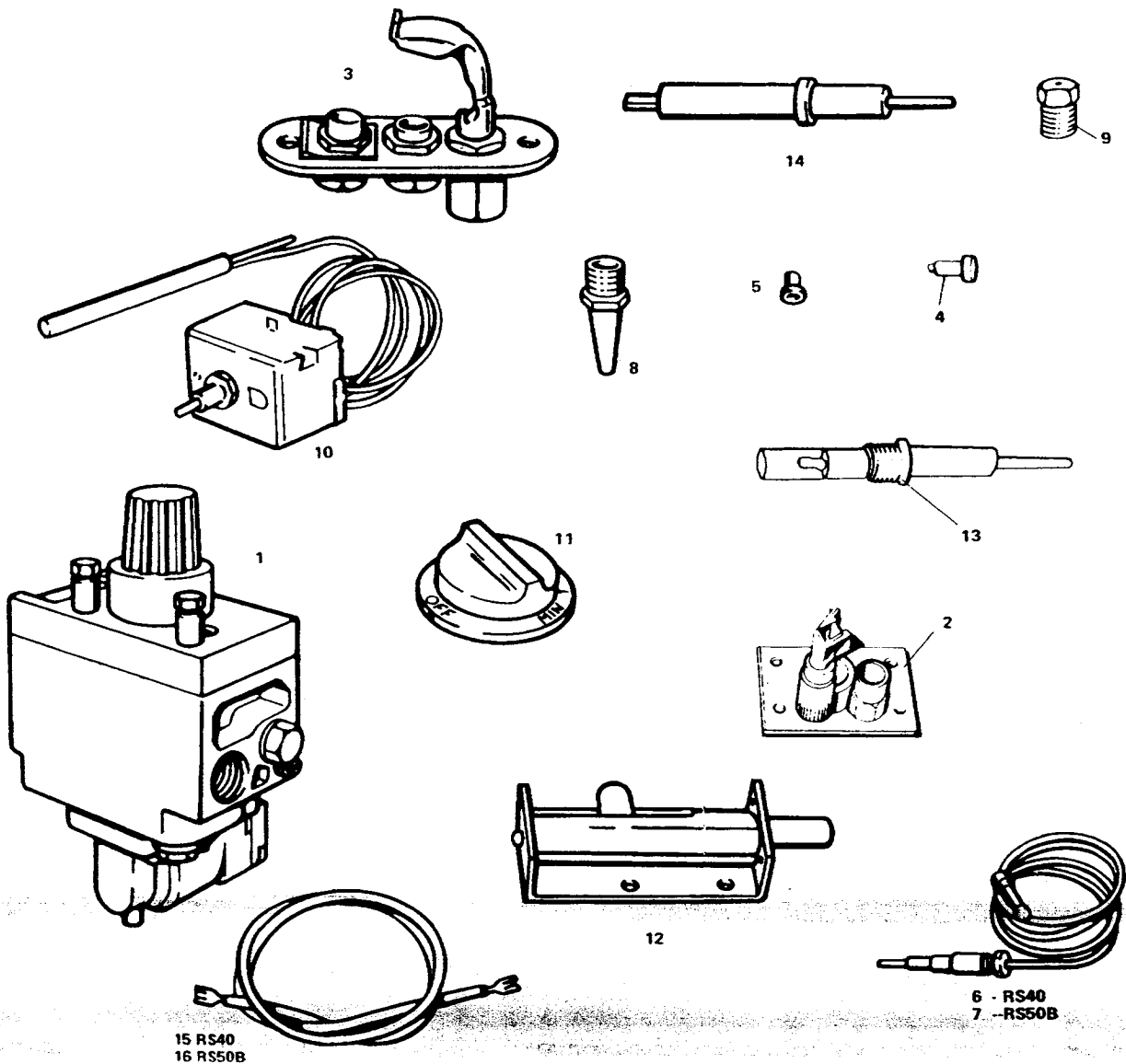

FIG. 19 FUNCTIONAL FLOW DIAGRAM (for Overheat Thermostat Kit)

11. SHORT PARTS LIST

Item No.		Description	Potterton Part No.	G.C. No.
RS 40	RS 50B			
1	1	Gas Control Valve S.I.T.	402923	381749
2	-	Pilot Burner Honeywell	402489	357800
-	3	Pilot Burner S.I.T.	402893	205208
4	-	Pilot Burner Injector	410209	390794
-	5	Pilot Burner Injector	402926	381949
6	-	Thermocouple	402174	390210
-	7	Thermocouple	402905	381626
8	-	Main Burner Injector	410963	337176
-	9	Main Burner Injector	410964	398057
10	10	Thermostat	404486	381628
11	11	Thermostat Knob	206515	381629
12	12	Piezo Unit	407664	388032
13	-	Spark Electrode	407625	387999
-	14	Spark Electrode	402885	395677
15	-	Spark Lead	407665	336405
-	16	Spark Lead	407688	337155



SUPPLEMENTARY INFORMATION FOR OVERHEAT THERMOSTAT KIT

RS 40	RS 50B	Description	P.I.L. No.	G.C.No.
17	17	Boiler Control Thermostat	404491	381 752
18	18	Overheat Thermostat	404492	381 753
19	-	Thermocouple Interrupter Body	640846	
-	20	" " "	640845	
21	21	Thermocouple Interrupter Lead Assy	206753	337 174

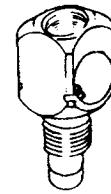
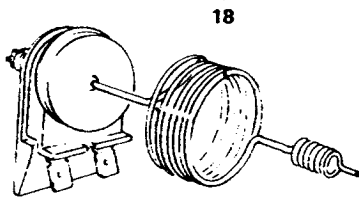

19 - RS40
20 - RS50

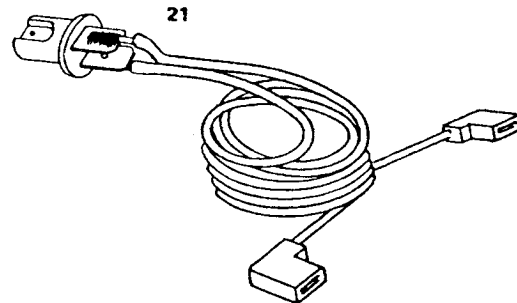
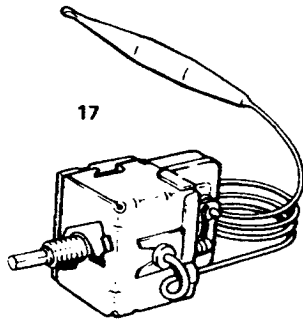

HEALTH AND SAFETY INFORMATION FOR THE INSTALLER AND SERVICE ENGINEER

Under the Consumer Protection Act 1987 and section 6 of the Health and Safety at Work Act 1974, we are required to provide information on substances hazardous to health.

Small quantities of adhesives and sealants used in the product are cured and present no known hazards.

The following substances are also present.

Insulation & Seals

Material	—	Ceramic Fibre; Alumino—Silicone Fibre
Description	—	Boards, Ropes, Gaskets
Known Hazards	—	Some people can suffer reddening and itching of the skin. Fibre entry into the eye will cause foreign body irritation. Irritation to respiratory tract.
Precautions	—	People with a history of skin complaints may be particularly susceptible to irritation. High dust levels are only likely to arise following harsh abrasion. In general, normal handling and use will not present discomfort, follow good hygiene practices, wash hands before consuming food, drinking or using the toilet.
First Aid	—	Medical attention must be sought following eye contact or prolonged reddening of the skin.

Thermostat

Material	—	Contains very small quantity of xylene.
Description	—	Sealed phial and capillary containing liquid.
Known Hazards	—	Irritating to skin, eyes and throat. Vapour is harmful. Inflammable—do not extinguish with water.
Precautions	—	Do not incinerate. Avoid contact with broken/leaking phials. Do not purposely puncture.
First Aid	—	Eye/skin contact, wash with clean water, seek medical attention.

Sales Enquiries:

Sales Department,
Eastern Avenue,
Team Valley Trading Estate,
Gateshead,
Tyne & Wear NE11 0PG.

Tel: 0191 491 4466
Fax: 0191 491 7568

Service Enquiries:

Service Department,
Brooks House,
Coventry Road,
Warwick,
CV34 4LL

Tel: 01926 496896
Fax: 01926 410006

Spares Enquiries:

Parts Division,
Queensway,
Leamington Spa,
Warwickshire,
CV31 3RG.

Tel: 01926 880600
Fax: 01926 880680

Technical Helpline:

Technical Department,
Brooks House,
Coventry Road,
Warwick,
CV34 4LL

Tel: 01926 410044
Fax: 01926 410006

Training Administration:

Unit 5, Titan Business Centre,
Spartan Close,
Tachbrook Park,
Leamington Spa,
Warwickshire CV34 6RS

Tel: 01926 430481
Fax: 01926 882971

Made in England by: Potterton Myson Limited
Registered Office: 84 Eccleston Square, London SW1V 1PX.
Registered No: 412935

POTTERTON

All descriptions and illustrations provided in this leaflet have been carefully prepared, but we reserve the right to make changes and improvements in our products which may affect the accuracy of the information contained in this leaflet.

All goods are sold subject to our standard conditions of sale which are available on request.

Publication No. 559863/0396