

# INSTALLATION & SERVICING INSTRUCTIONS

# ATAG

## Blauwe Engel



These instructions to be retained by user.

CE PIN 0063AS3538

# ATAG



---

## Contents

---

1	Introduction .....	4
2	Regulations .....	4
3	Description of the appliance .....	5
4	Scope of the supply .....	5
5	Mounting of the boiler .....	5
5.1	Dimensions .....	6
6	Connecting the boiler .....	7
6.1	Central heating system .....	8
6.2	Expansion vessel .....	9
6.3	Underfloor heating systems (plastic pipes) .....	10
6.4	Gas connection .....	10
6.5	Hot water supply (S-HR-T) .....	11
6.6	Hot water supply S-HR 15, 24 and 35 .....	11
6.7	Condensation drain pipe .....	11
6.8	Flue gas exhaust system and air supply system .....	12
7	External hot water cylinders .....	14
8	Electrical connection .....	14
9	Boiler controls .....	16
9.1	Explanation of the function keys .....	16
10	Filling and venting the boiler and installation .....	17
10.1	Central heating system .....	17
10.2	Hot water supply .....	17
11	Commissioning the boiler .....	18
11.1	Central Heating system .....	18
11.2	Hot water supply .....	18
11.3	Adjustments .....	18
12	Isolating the boiler .....	21
13	Commissioning .....	22
13.1	Checking for contamination .....	22
13.2	Checking of the zero pressure control .....	22
13.3	Checking the CO <sub>2</sub> .....	23
14	Maintenance .....	24
14.1	The frequency of maintenance .....	24
14.2	Maintenance activities .....	24
14.3	Further checks .....	24
15	Technical specifications .....	25
16	Diagram showing various parts of the boiler .....	26
17	Example diagrams for connecting the boiler .....	28
17.1	Radiator installation without thermostat valves .....	28
17.2	radiator installation with thermostat valves only .....	29
18	Error indication .....	30
19	CE-Certificate United Kingdom .....	31
20	CE-Certificate Ireland .....	32



**The appliance should only be installed by a Competent Gas Installer.**

---

## 1 Introduction

---

These instructions describe the functioning, installation, use and primary maintenance of ATAG central heating units for United Kingdom and Ireland. Where necessary different regulations of each country are separately described.

These instructions are intended for the use of Corgi registered installers or registered Bord Gais installers in connection with the installation and putting into operation of ATAG units. It is advisable to read these instructions thoroughly, well in advance of installation. Separate instructions for use are supplied with the unit for users of ATAG central heating units. ATAG is not liable for the consequences of mistakes or shortcomings which have found their way into the installation instructions or user's manual. Further, ATAG reserves the right to alter its products without prior notification.



**When delivering the unit, give the customer clear instructions concerning its use; present the customer with the user's manual and card.**

Each unit is fitted with an identification plate. Consult the details on this plate to verify whether the unit is compliant with its intended location, e.g.: gas type, power source and exhaust classification.

On completion of the installation the installer or commissioning engineer must fill out and complete the Benchmark commission section of the boiler log book and hand to customer or end user for future record keeping. The Benchmark log book must also be filled out and completed by the service agent following each service call, and returned to the customer. A copy of the Benchmark commissioning certificate must be returned to ATAG Heating UK Ltd along with the warranty registration card to register the appliance for the standard warranty benefits.

---

## 2 Regulations

---

The following regulations apply to installation of ATAG central heating units:

Legislation and Regulations.

Gas Safety (Installation and Use). All gas appliances must by law, be installed by a competent person, eg. Members of CORGI and in accordance with the current Gas Safety Regulation. Failure to install appliance correctly could lead to prosecution.

In addition to the above regulations this appliance must be installed in compliance with the current IEE Regulations, the Building Standards (Scotland Consolidation) Regulations. Regulations and bye laws of the Local Water Authority and the Current Health and Safety Regulation.

### **Ireland:**

- Irish standard 813
- Domestic gas installations

The current, Electricity at Work Regulation must be complied with and also be in accordance with the relevant and current editions of the British Standards.

The ATAG Blauwe Engel boiler is a certified appliance and must not be modified or installed in any way contrary to this Installation Manual.

Manufactures instructions must not be taken in any way as overriding statutory obligations.

The ATAG Blauwe Engel is a central heating unit with an optional integrated hot water function. These units must be connected according to these instructions and all installation norms in respect of the part of the unit to be connected.

Observe the following rules of safety:

- All work on the unit must take place in a dry environment.
- ATAG units may never be in operation without their housing, except in connection with maintenance or adjustments (see Chapter 13 and 14).
- Never allow electrical or electronic components to come into contact with water.

Carry out the following tasks in connection with maintenance, etc. to an already-installed unit:

- Shut down all programmes
- Close the gas tap
- Remove the plug from the wall socket
- Close the stop cock of the unit's intake connection

Take note of the following when maintenance or adjustments are needed:

- The unit must be able to function during these activities; for this reason, the unit's supply voltage, gas pressure and water pressure must be maintained. Ensure that these are not a source of potential danger during these activities.



**Following maintenance or other activities; always check the installation of all parts through which gas flows (using leak-search spray).**



**Following maintenance or other activities, always replace the housing and secure it with the screw behind the door at the front of the casing.**

The following (safety) symbols may be encountered in these installation instructions and on the unit:



**This symbol indicates that the unit must be stored away from frost.**



**This symbol indicates that the packaging and/or contents can be damaged as a result of insufficient care taken during transport.**



**This symbol indicates that, whilst still in its packaging, the unit must be protected from weather conditions during transport and storage.**



**KEY-symbol. This symbol indicates that assembly or dismantling, must be carried out.**



**ATTENTION symbol. This symbol indicates that extra attention must be paid in connection with a particular operation.**



**Danger: High Voltage!**

---

### 3 Description of the appliance

---

The ATAG Blauwe Engel S-HR boiler is a room sealed, condensing and modulating central heating boiler, with or without an integrated hot water facility.

The built-in fan sucks the combustion air from outside and provides full premixing of the gas and air. The gas mixture is guided through the ceramic burner which is fitted above the heat exchanger. As a result of the small flame height a compact construction is possible. The combustion gasses are exhausted after passing through the stainless steel heat exchanger. The formed condensate water is discharged through the waste trap.

The boiler has been tested according to valid CE\* standards and has a CE\* certificate and SEDBUK A-rating.

The operating efficiency of the boiler is higher than 98% (on upper value Hs). As a result of its compact construction the radiation, convection and stand by losses are very low. The emission of damaging substances is far below the standard set for equipment with the gas quality-control label for clean combustion.

The boiler is provided with an automatic venting program. In case of a recently topped up or filled up installation this program takes care of the removal of any present air in the boiler. In this case the control will check the water pressure and if it is too low, will report this on the display.

The boiler anticipates the heat requirement of the central heating installation or the hot water supply. As a result the boiler will adjust its capacity to the installation and will switch on less often, which means that the boiler will operate longer and at a low level. It is possible that the boiler

will only have to switch on once an hour. In this case the aim is to obtain maximum comfort and efficiency.

In order to be able to anticipate installation heat emissions the boiler has been fitted with a proportional gradient control system. After the boiler goes into operation this control provides a uniform increase of power, instead of immediately burning at full power. When the installation does require full power the control will adjust as required. By this means a uniform increase of the water temperature is effected.

If an outside sensor is connected, the control will operate weather-dependent. This means that the control measures the outside temperature and the flow water temperature. On the basis of this data the control calculates the optimal flow water temperature in the installation.

The S-HR-T combination boiler provides a hot water supply by means of a high output cylinder fitted on the right hand side of the boiler. An adjustable thermostatic mixing valve is fitted which provides a constant hot water temperature (60°C factory setting).

---

### 4 Scope of the supply

---

The boiler is supplied ready for use. The supply kit is composed as follows:

- Boiler with casing;
- Automatic vent (inside the boiler);
- Safety valve (inside the boiler);
- Suspension bracket
- Filling and draining valve with T-piece;
- Fixing material consisting of plugs and screws;
- Template on the package wrapper;
- Installation instructions
- Operating manual;
- Warranty card;
- Benchmark logbook.

---

### 5 Mounting of the boiler

---

The boiler can be mounted practically to any wall with the suspension bracket and the enclosed fixing equipment. The wall must be flat and of sufficient strength in order to be able to carry the boiler weight.

Above the boiler there must be at least 250 mm working space in order to be able to fit a coaxial flue system or a twin supply. On the left side of the boiler at least 50 mm and on the right side 10 mm must be reserved in connection with fitting or removing of the casing. The location of the boiler can be determined by using the template located inside the boiler packaging.

## 5.1 Dimensions

	type of unit		S-HR 15	S-HR 24	S-HR 24T	S-HR 35	S-HR 35T	S-HR 51	S-HR 51T	S-HR 60
A	height	mm	680	680	680	680	680	680	680	680
B	width	mm	500	500	840	500	840	660	1000	660
C	depth	mm	370	370	370	370	370	370	370	370
D	left side / flue gas concentric	mm	335	335	335	335	335	495	495	495
E	centre to centre / flue gas exhaust and supply	mm	120	120	120	120	120	120	120	120
F	back / flue gas exhaust	mm	270	270	270	270	270	270	270	270
G	left side / gas pipe	mm	65	65	65	65	65	65	65	65
H	left side / flow pipe	mm	185	185	185	185	185	185	185	185
J	left side / return pipe	mm	285	285	285	285	285	445	445	445
K	left side / condensation pipe	mm	370	370	370	370	370	530	530	530
L	left side / expansion tank pipe	mm			430		430		590	
M	left side / cold water pipe	mm			725		725		885	
N	left side / hot water pipe	mm			795		795		955	
P	left side / return pipe DHW	mm	475	475		475				
Q	pipe length of g*	mm	18	18	18	18	18	18	18	18
R	pipe length of c and k*	mm	40	40	40	40	40	40	40	40
S	pipe length of f; r; e and w*	mm	60	60	60	60	60	60	60	60
T	back / centre of pipe c*	mm	25	25	25	25	25	25	25	25
U	back / centre of pipe g*	mm	40	40	40	40	40	40	40	40
V	back / centre of pipe f;r;e;k;w*	mm	50	50	50	50	50	50	50	50

Dimensions (\* see figure 2)

table 1

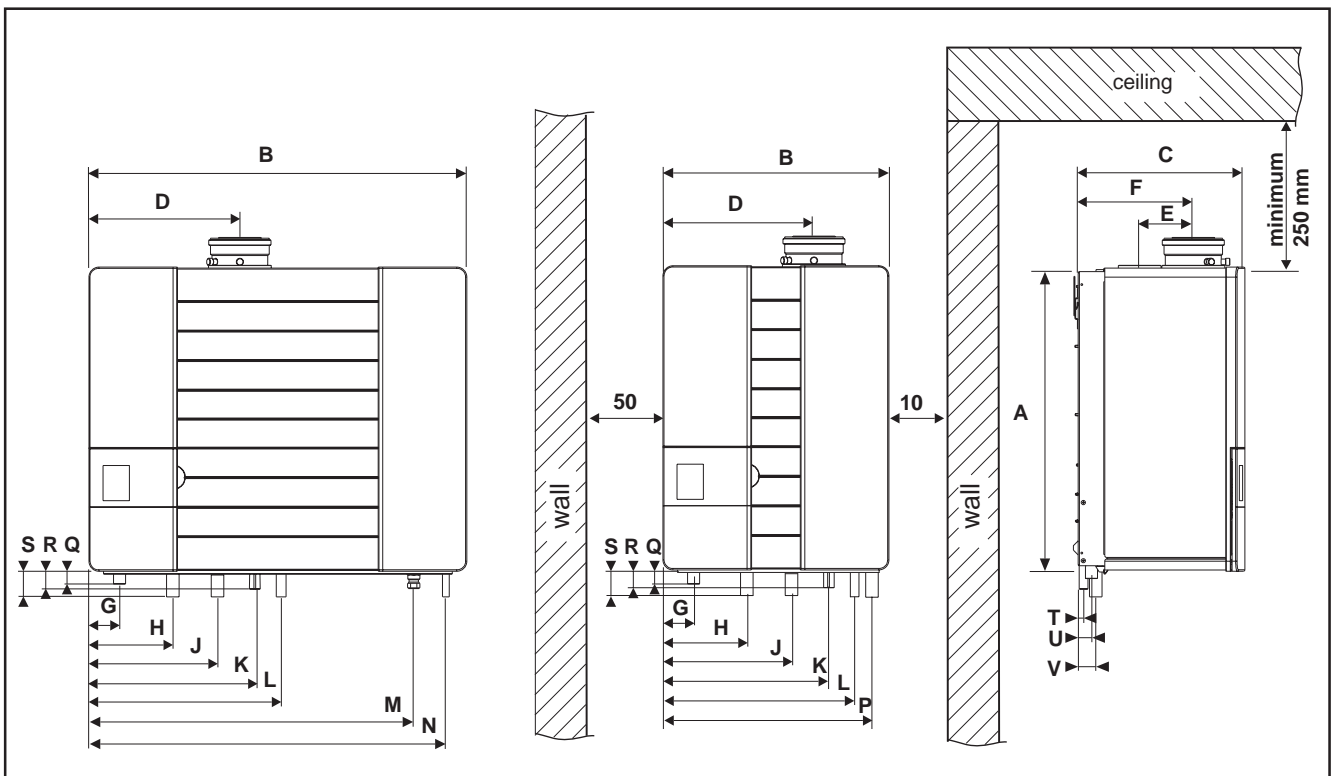

Dimensions (in mm)

figure 1

type of unit		S-HR 15	S-HR 24	S-HR 24T	S-HR 35	S-HR 35T	S-HR 51	S-HR 51T	S-HR 60
combustion air supply/flue gas exhaust	mm	80/125	80/125	80/125	80/125	80/125	80/125	80/125	80/125
gas pipe - g		½" inside	½"inside	½" inside	½" inside	½" inside	¾" inside	¾" inside	¾"inside
central heating flow pipe - f	mm	28	28	28	28	28	35	35	35
central heating return pipe - r	mm	28	28	28	28	28	35	35	35
condensation discharge pipe - c	mm	24	24	24	24	24	24	24	24
expansion vessel pipe - e	mm	22	22		22			22	
cold water pipe - k	mm			15		15		15	
hot water pipe - w	mm			15		15		15	
return pipe DHW - d	mm	28	28		28				

connection diameters

table 2

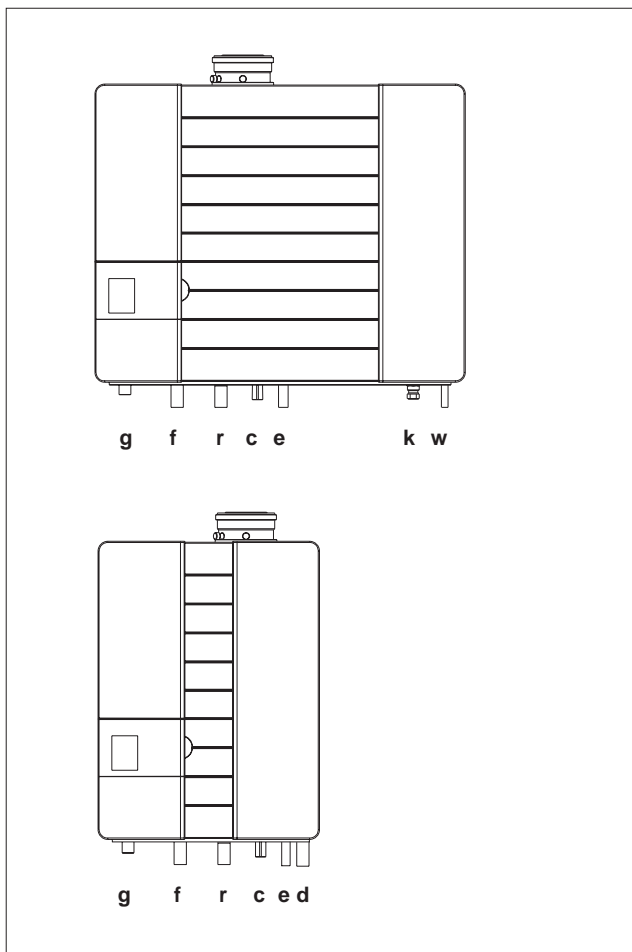

boiler pipes bottom

figure 2

## 6 Connecting the boiler

The boiler has the following connection pipes;

- The central heating pipes.  
*These can be connected to the installation by means of compression fittings;*
- The gas pipe.  
*It is provided with a female thread into which the tail piece of the gas valve can be screwed;*
- The condensation drain pipe.  
*It consists of an oval 24 mm plastic pipe. The drain pipe can be connected to this by means of an open connection. If the open connection is fitted in a different location, then the pipe can be lengthened by means of a 32 mm PVC sleeve;*
- The flue gas exhaust system and air supply system.  
*It consists of a concentric connection 80/125 mm.*
- Cold and hot water pipes.  
*These consist of 15 mm copper pipe and can be connected to the installation by means of compression fittings.*



**When removing the plastic sealing caps from the pipes, contaminated testing water can be released.**



**It is advisable to spray-clean all of the unit's connecting pipes and/or to spray-clean/blow-clean the installation before connecting it to the unit.**

## 6.1 Central heating system

The boiler pipes can be connected to the installation by means of compression fittings. Reducers should be used for connecting to thick-walled pipe (welded or threaded).

The boiler has a self-adjusting and self-protecting control system for the load and the pump capacity. By this means the temperature difference between the flow and return water is checked. The circulation pump will be able to supply the given water displacement with an installation resistance of up to 20 kPa, for this see table 3.

type of unit	Pump type	water flow rate $\Delta T$ 20°C		permissible installation resistance	
		l/min	l/h	kPa	mbar
<b>S-HR 15</b>	20-60	9,5	570	42	420
<b>S-HR 24/24T</b>	20-60	15,1	908	30	300
<b>S-HR 35/35T</b>	20-60	22,1	1324	20	200
<b>S-HR 51/51T</b>	20-70	32,1	1924	25	250
<b>S-HR 60</b>	20-70	37,8	2267	20	200

available water flow at full load

table 3

the pump will rotate at maximum pump capacity and the load will be adjusted until an acceptable temperature difference between flow and return water has been obtained. If, after this, the temperature difference remains too much then the boiler will switch itself off and wait until an acceptable temperature has arisen.

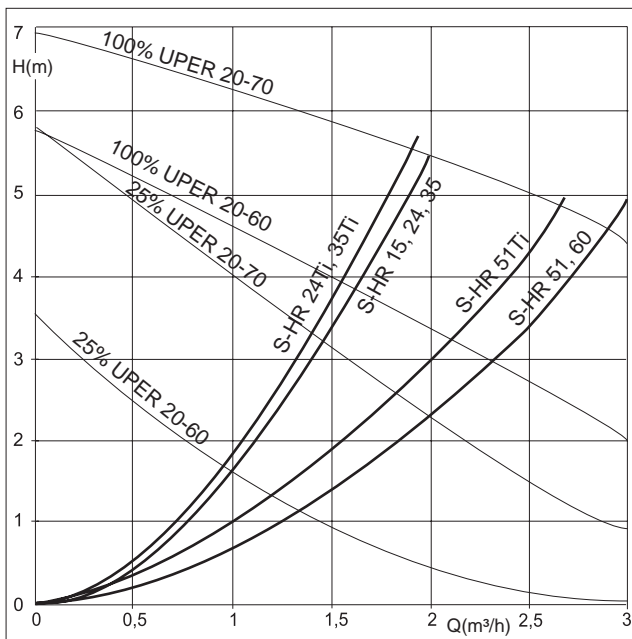

pump index lines

graph 1

If an unacceptable temperature is detected, then the control will repeatedly try to achieve water flow, and if this does not work then the boiler will switch off.

The S-HR 60 boiler has a circulation pump which has a residual suction head for the installation of 20 kPa. This means that the boiler can function normally in installations which have an installation resistance of up to 20 kPa and in cascade installations.

If the installation resistance is higher than 20 kPa, the boiler will automatically reduce in power.

If the capacity of the boiler pump is insufficient, an extra external pump can be installed in series with the boiler. The electrical side of this external circulation pump can be connected in the Control Tower, by which means this pump switches at the same times as the boiler pump. The maximum absorbed current consumption of the external circulation pump may be 230 W (1 Amp). Use with a low velocity header can also be selected. In this case a larger secondary sided water output has to be taken into account, in order to affect the maximum water temperature.

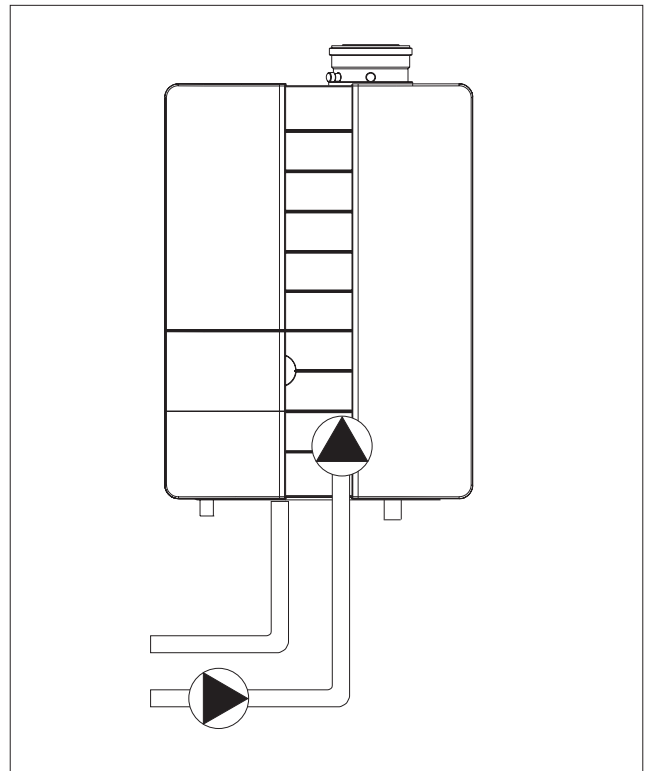

external installation pump in series

figure 3



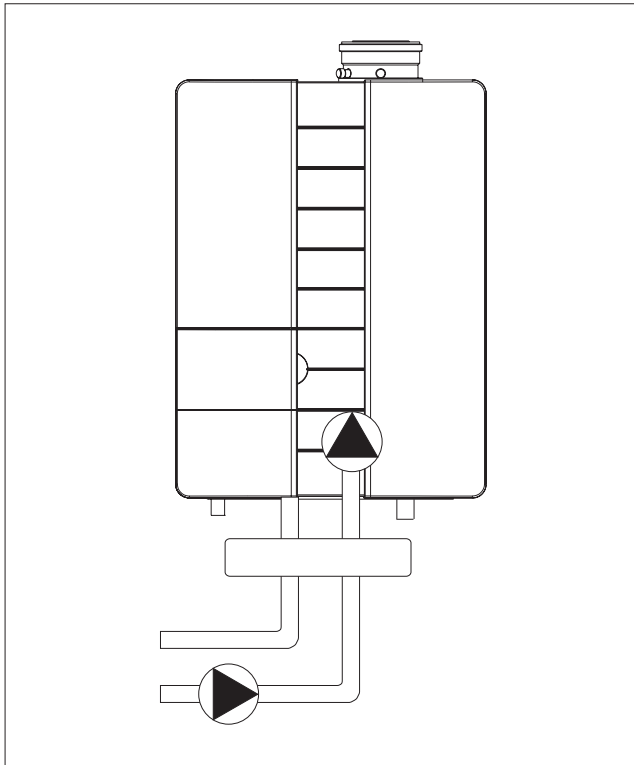

external installation pump with low velocity header figure 4

As standard the boiler is provided with a water filter in the return pipe of the boiler. With this, possible contamination of the central heating water is prevented from ending up in the boiler. The boiler is also provided with an internal safety valve set at 3 bar. This is connected to the waste discharge together with the condensation discharge.

**If all, or a large part of the radiators are provided with thermostatic radiator valves it is advisable to use a pressure difference control (bypass) in order to prevent flow problems in the installation.**

**! The boiler is designed to be used on sealed system only.**

**! Additives in the installation water are only permitted in consultation with the country distributor.**

When using more than one boiler in an installation please refer to the cascade installation instructions.

## 6.2 Expansion vessel

All ATAG Blauwe Engel S-HR-24T and 35T boilers are provided with an expansion vessel on top of the cylinder. This expansion vessel is connected to the three-way valve and the circulation pump. By this means the expansion water, when functioning for the hot water supply, is prevented from being shut off from the expansion vessel when the radiator thermostat valves are fully closed. The ATAG Blauwe Engel S-HR 51T is provided with an expansion vessel connection. The expansion vessel of correct size must be connected to this pipe. A second expansion vessel in the installation is not a problem.

The ATAG Blauwe Engel S-HR boilers are not equipped with an expansion vessel connection. If a S-HR boiler is combined with an Comfort cylinder, the expansion vessel connection is included in the internal piping of the Comfort cylinder, to which the expansion vessel can be connected. If a different cylinder is used then one has to take into account that the expansion vessel should be connected between the three-way valve and the boiler circulation pump.

**! In connection with correct functioning of the boiler it is necessary for the expansion vessel to be connected to the expansion vessel pipe of the boiler.**

The expansion vessel which is used should be geared to the water content of the installation. The pre-charge pressure depends on the installation height above the mounted expansion vessel.

installation height above the expansion vessel	pre-charge pressure of the expansion vessel
5 m	0,5 bar
10 m	1,0 bar
15 m	1,5 bar

choice of expansion vessel

table 4

The ATAG S-HR24 and S-HR35 boilers can be provided with an expansion vessel module. By this means the external expansion vessel is cancelled. This expansion vessel module is placed behind the S-HR boiler, by which means the expansion vessel is not noticeable. If the S-HR boiler is provided with a ATAG Comfort cylinder the overall depth will be equal. The content of the two expansion vessels is 20 litres. The pre-charge pressure is 1 bar.

The expansion vessel module can be supplied with the necessary pipes to connect with the S-HR boiler. The connecting pipes for the installation correspond with those of the boiler and have the same centre-to-centre distance to the wall. When checking the expansion vessels these are accessible via the left, right and upper sides. From these sides the tanks are also removable and the boiler does not have to be dismantled.

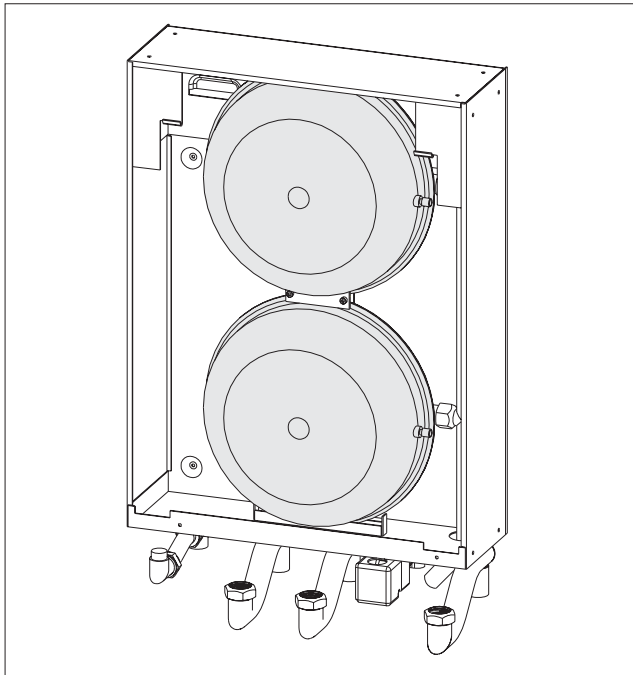

expansion vessel module

figure 5

The space which is required for mounting the expansion vessel module corresponds with the required space for mounting an S-HR boiler. They included template and mounting strip for the S-HR boiler which can be used for the expansion vessel module. The S-HR boiler is fitted on to this after the expansion vessel module has been mounted. The necessary mounting strip for the boiler is present on the module.

Article numbers:

- the expansion vessel module without pipe connections AA1EM09U
- pipe connections for expansion vessel module AA1LE04U

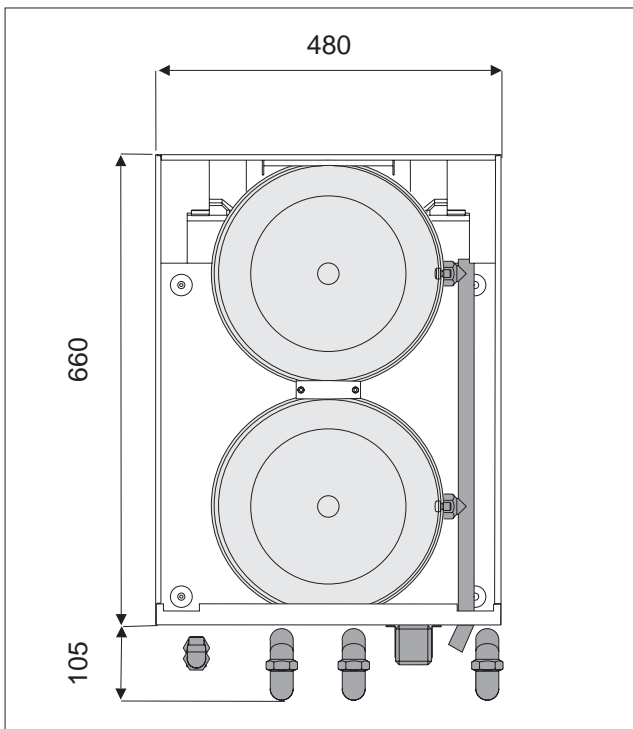

front view of the expansion vessel module  
(dimensions in mm)

figure 6

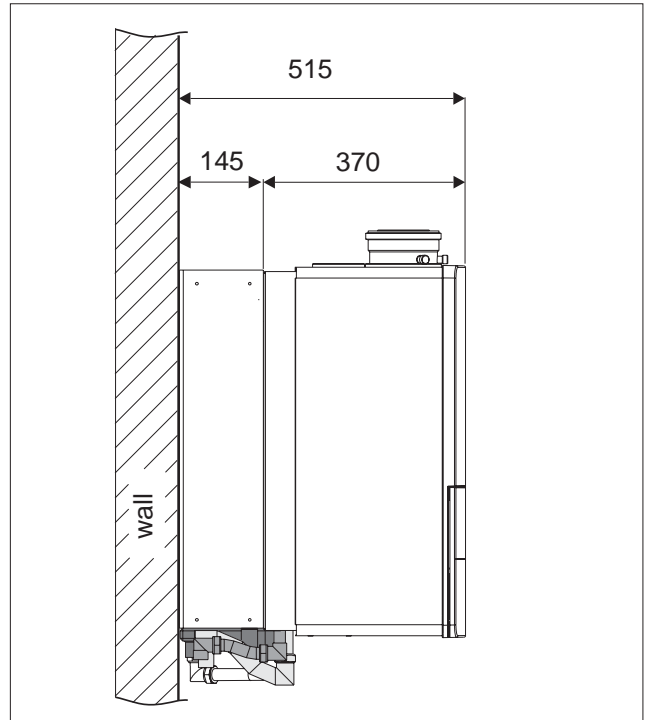

side view of the module with S-HR boiler  
(dimensions in mm)

figure 7

### 6.3 Underfloor heating system (plastic pipes)

When connecting or using an underfloor heating system, designed with plastic pipes, or plastic pipes are used elsewhere in the installation, one should ensure that the plastic pipes used comply with the DIN 4726/4729 standard. It is set out in this standard that the pipes may not have oxygen permeability higher than 0.1 g/m<sup>3</sup>.d at 40°C. If the system does not comply with this DIN standard, the underfloor heating component will have to be separated from the central heating appliance by means of a plate exchanger.



**No recourse can be made to the terms of the warranty in the event of failure to observe the regulations pertaining to plastic underfloor heating pipes.**

## 6.4 Gas connection

---

The appliance pipe is fitted with an internal thread, into which the tail piece of the gas tap can be screwed.

### **United Kingdom:**

The gas supply must comply to the current Gas Safety Regulations.

### **Ireland:**

- Irish standard 813
- Domestic gas installations

The connection to the appliance must include a suitable method of disconnection and a gas control cock must be installed adjacent to the appliance for isolation purposes. The nominal inlet working gas pressure measured at the appliance should be 20 mbar for Nat gas (G20).



**Make sure that the gas pipe work does not contain dirt, particularly with new pipes.**

## 6.5 Hot water supply (S-HR-T)

---

The sanitary water pipes can be connected to the installation by means of compression fittings.

The cold water inlet on the S-HR-T boilers must be provided with the following (counted in the water flow direction):

- Dosing valve (supplied);
- Safety group;
- Expansion vessel 6bar (potable water, blue).

A dosing valve must be fitted in the cold water pipe. The dosing valve provides that a quantity of water is supplied which has a guaranteed outlet temperature of 60°C (assuming a cold water temperature of 10°C). The quantity of water is virtually unaffected by the water pressure. With a water pressure lower than 1.5 bar it is advisable to remove the inside mechanism of the dosing valve. Connecting of the drinking water installation should be done according to the national water laws.

## 6.6 Hot water supply S-HR 15, 24 and 35

---

Depending of the comfort preferences different external hot water cylinders can be connected to the boiler. The choice of the cylinder depends on the coil output. The coil output must comply with the boiler output. The S-HR 15, 24 and 35 are provided with an internal 3 way valve. The return pipe of the cylinder is simply connected to the connection under the boiler. The flow pipe of the cylinder must be connected to a T-piece in the flow pipe of the boiler. The electrical connection are already made on the connection terminal in the Control Tower. Only the wire of the cylinder sensor should be connected to the terminal. See the wiring diagram on page 14 and 15.

By the SH-R 51 and 60 with larger cylinder pipes (coil resistance) we recommend the use of a cylinder pump.

## 6.7 Condensation drain pipe

---

The collective condensation drain pipe should be connected to the drain by means of an open connection. By this means the possibility of drain gases ending up in the boiler is prevented. The drain connection should have a minimum diameter of 25 mm.

The following components are connected to the collective condensation drain pipe:

- Condensation discharge;
- Safety valve;



**Draining of the condensation water to the external rain guttering is not permitted in view of the danger of freezing.**



**Before putting the boiler into operation fill the siphon with 300 ml of water.**

## 6.7 Flue gas exhaust system and air supply system

The appliance connection diameter is 80 mm, to which the flue gas outlet and air supply system can be fitted, with or without elbow pieces. It is also possible to use a concentric connection. The maximum permissible pipe length is set out in Table 5.

It is also possible to use a parallel pipe connection of 2x 80mm. In this case a separate cover 125mm should be ordered.

### United Kingdom:

The flue gas outlet and air supply installation must comply with the current regulation requirements. IG UP 10 and BS 715.

### Ireland:

- Irish standard is 813 section 9.10.1

The complete flue gas and air supply system includes the flue gas discharge duct and the roof or wall terminal. The maximum stated pipe length in metres is for the supply / exhaust system and is the distance between the unit and the roof or wall terminal.	
type of unit	maximum linear pipe length in metres with 80 / 125 mm
S-HR 15	17
S-HR 24/24T	17
S-HR 35/35T	11,5
S-HR 51/51T	5
S-HR 60	2,5
When using bends in the supply or exhaust system, the equivalent length stated below, must be added to the linear pipe lengths. Example: S-HR 24 with 10 metres exhaust duct 80 / 125 mm and 2 x 90° bends. This means: 10 metres + 2 x 1,2 metre = 12,4 metre. This is within the maximum permitted length.	
bend 90°	1,2
bend 45°	1,0

length supply and exhaust system

table 5

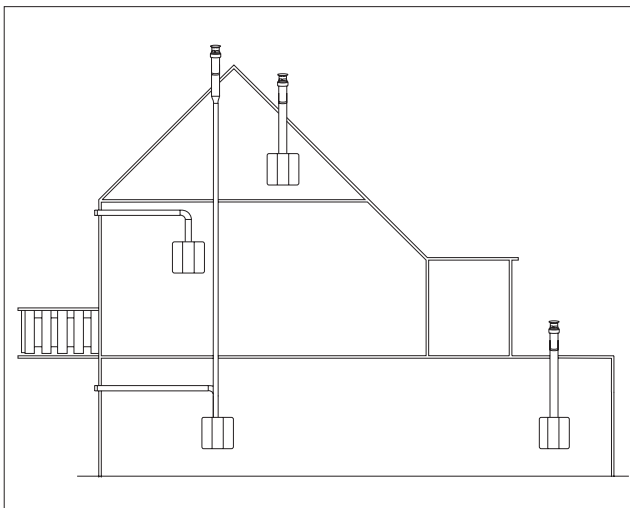

supply and exhaust system

figure 8

We recommend that you use a stainless steel flue gas outlet material. Using the ATAG icicle-free roof outlet prevents ice from building up on the roof outlet.

Flue systems must comply with the current regulations. It is essential that in practice, products of combustion discharging from the terminal cannot re-enter the building or any other adjacent building through ventilators, windows, doors, other sources of natural or mechanical air infiltration from forced ventilation or air conditioning systems.

Horizontal sections of flue sections of the flue system should always be installed sloping towards the boiler, in order to avoid condensate lying in the flue system.

The minimum gradient is 30mm/Mtr. With the condensate running back to the boiler the risk of ice forming at the terminal is reduced.

The terminal should be located where dispersal of combustion products is not impeded and with due regard for the damage or discolouration that might occur to building products in the vicinity (see fig 9).

In certain weather conditions condensation may also accumulate on the outside of the air inlet pipe. Such conditions must be considered and where necessary insulation of the inlet pipe may be required.

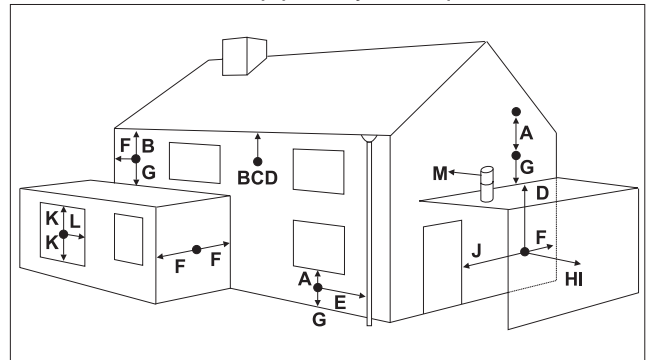

figure 9

terminal position for fan assisted boiler		minimum distance
A directly below an open window or other opening (e.g. air brick)	mm	300
B below gutters, soil pipes or drain pipes	mm	75
C below eaves	mm	200
D below balconies or car port roof	mm	200
E from vertical drain pipes and soil pipes	mm	75
F from internal or external corners	mm	300
G above ground or below balcony level	mm	300
H from a surface facing a terminal	mm	600
I from a terminal facing a terminal	mm	1200
J from an opening in the car port (e.g. door window) into dwelling	mm	1200
K vertically from a terminal on the same wall	mm	1500
L horizontally from a terminal on the same wall	mm	300
M horizontally from a vertical terminal to a wall	mm	300

Dimensions

table 6

In cold and/or humid weather water vapour may condense on leaving the flue terminal. The effect of such 'steaming' must be considered.

The terminal must not be located in a place where it is likely to cause a nuisance.

For protection of combustibles, refer to IS 813 section 9.10.1. where the terminal is less than 2m (6.6ft) above a pavement or platform to which people have access (including) any balcony or flat roof the terminal must be protected by a guard of durable material.

A suitable guard is available from the country distributor.



**Where a terminal is fitted below a window which is hinged at the top, and where the hinge axis is horizontal, and the window opens outwards, the terminal shall be 1m below the bottom of the window opening.**



**If the boiler is to be located under stairs, a smoke alarm meeting the requirements of I.S. 409 or equivalent must be fitted.**



**The flue must be terminated in a place not likely to cause a nuisance.**

For horizontal sections, the outlet system should always be fitted on an incline (30 mm/m) sloping down towards the appliance so that no condensation water is able to accumulate in the outlet system. The chances of icicles forming on the roof outlet is minimised by causing the condensation water to run back towards the appliance. In the case of horizontal outlets the inlet system should be fitted on an incline sloping down towards the outside to prevent rainwater from coming in.

Fitting an additional condensation collection device in the outlet system is surplus to requirement.

The appliance produces a white wisp of condensation. This wisp of condensation is harmless, but can be found to be unpleasant, particularly in the case of outlets in outside walls.



**The appliance is not suitable as an "open" appliance. This means that combustion air should always be obtained through a direct connection.**



**For further information regarding the supply range of the exhaust and supply system please contact the country distributor.**

## 7 External hot water cylinders

Various external hot water cylinders can be connected to a S-HR boiler, depending on the hot water requirements. The wiring of the cylinder thermostat can be connected to the connection block in the Control Tower by means of the relevant plug.



### **S-HR51 and S-HR60**

**Consult your supplier when using cylinders with lower absorption than 35kW or primary pipe and/or coil size less than 1 inch.**

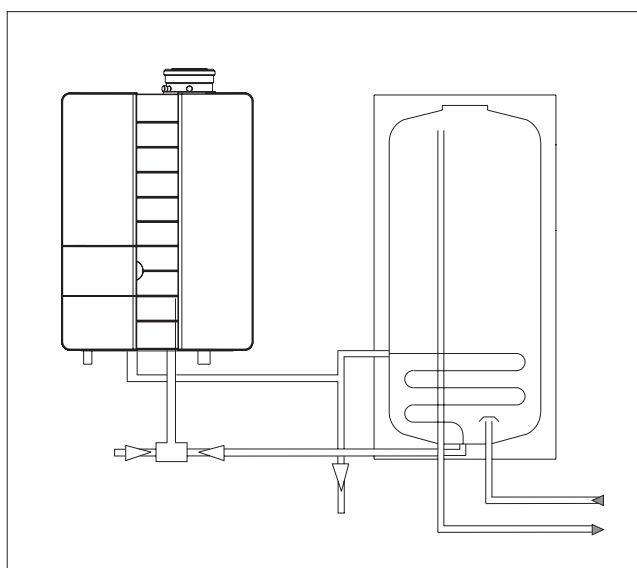

S-HR with external cylinder

figure 10

## 8 Electrical connection

The appliance complies with the CE Machinery Directive 89/392/EEC. The EC Low Voltage Directive 72/23/EEC and the EC EMC Directive 89/336/EEC.

A 230V -50Hz mains electrical supply is required fused externally at 5A.

The installation must continue to comply with:

### **United Kingdom:**

- the national rules for electrical installations.

### **Ireland:**

- the ECTI national rules for electrical installations

The appliance must be connected to an earthed socket. this must be visible and within reach.

The following general stipulations also apply:

- No changes may be made to the wiring of the appliance;
- All connections should be designed in accordance with the enclosed regulations.;
- Should it be necessary to change it, the mains power supply cable may only be replaced with an ATAG mains power supply cable (item No. S4407300).

**The ATAG room thermostat and controls must be connected to their allocated connections. All other types or makes of room thermostats or controls which are used must have a Volt free contact.**

When using an on/off thermostat or control, it is possible that an anticipating resistance must be installed in order to prevent too high temperature fluctuations. As a standard rule this means mercury thermostats. This resistance wire is present in the Control Tower and must be connected to clamps 23 and 27. The anticipating resistance in the room thermostat has to be set at 0.11 A.

For more detailed questions regarding the components which are not supplied, the country distributor should be contacted.



**All electrical connections must be done on the connection block in the Control Tower.**

### Connection block in the Control Tower

230 V~ Power Supply			230 V~ External Pump			230 V~ External Controller			230 V~		8G.35.22.01	Calorifier connection					Outside sensor		Brain		Room therm. On / Off		External safety contact		24 V~ 100 mA			
N	L		N	L		N	L		N	L		CH	DHW	N		DHW sensor	A	B										
1	2	3	4	5	6	7	8	9	10	11		12	13	14	15	16	17	18	19	20	21	22	23	24	25	26	27	
mains power supply			230 Volts for external pump			230 Volts for external control			230 Volts		internal or external three-way valve motor and cylinder sensor					ATAG outside sensor		ATAG room thermostat		On/off thermostat or control (Volt free)		External safety contact		24 Volts maximum 100 mA				

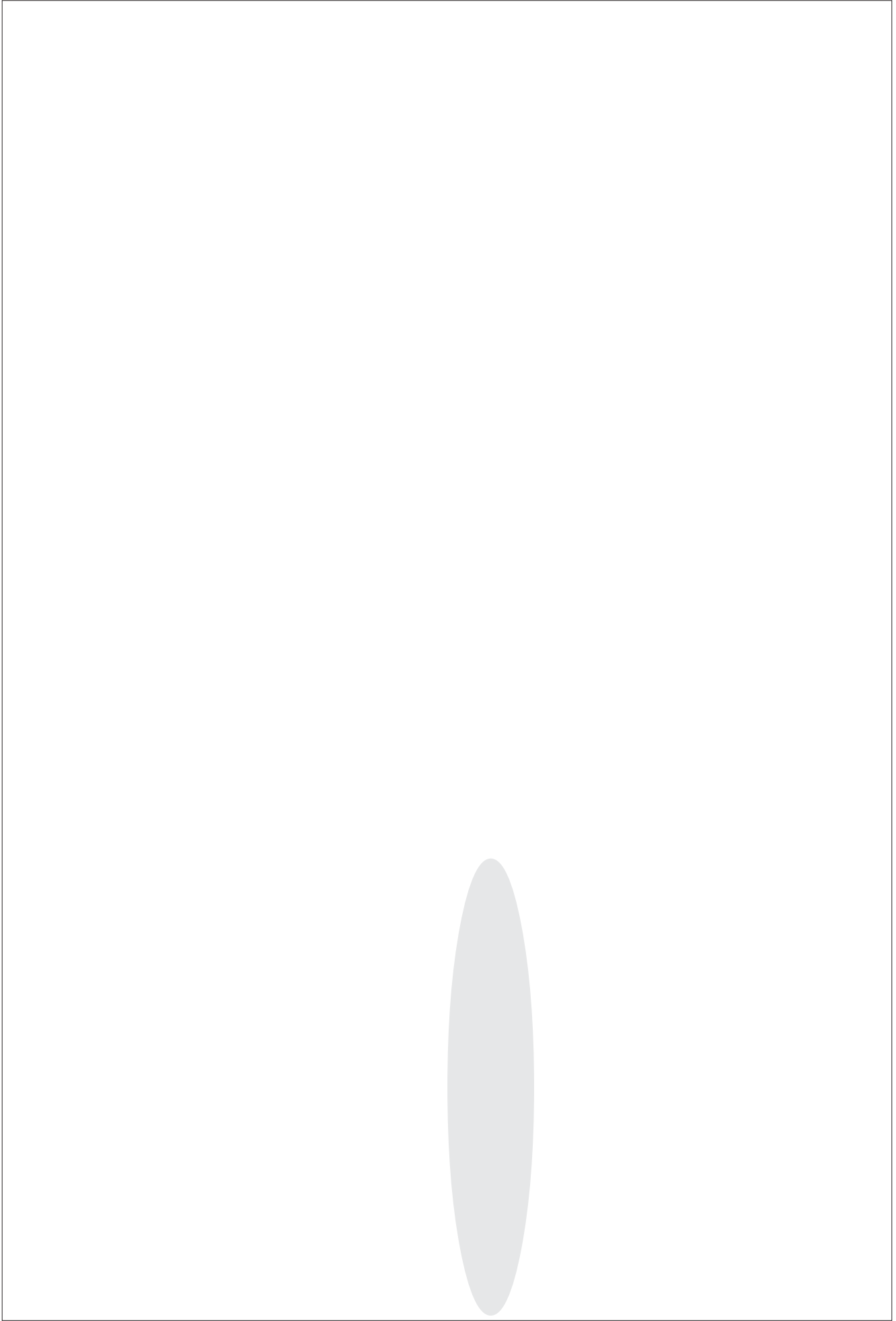

figure 11

electrical connecting diagram

---

## 9 Boiler controls

---

The boiler is provided with a fully automatic microprocessor control. This control simplifies operation by undertaking all major control functions. Initially when power to the unit is switched on it will remain on standby. The control panel display will show the relevant state. The various parameters can be called up in two ways:

The **Load** state.

In this state the display will show **Load** during all normal operating functions of the appliance. Should a fault develop this will be shown on the display.

The technical read out.

Start from the **Load** state by pressing the Step key for 5 seconds. Returning from this to the **Load** display is done in the same way. From the technical read out a more extensive read out can be obtained e.g. the boiler flow temperature and the water pressure in the central heating system.

When the system has been filled and the automatic venting program starts, when a program has been selected, the program takes 15 minutes and stops automatically. After this the unit will function normally.



On a call for heating or hot water the control system will select the required water control temperature. This water temperature is called the T-set value. On a call for central heating the boiler ignites first at low input. The input is then changed slowly to match the load required. The boiler operates in this way to avoid excessive water noises and temperature overshoot. On a call for hot water supply the T-set value of central heating return water temperature is monitored. Depending on the amount of sanitary water which is withdrawn from the DHW cylinder, the central heating return water temperature, from which the input is adjusted, will vary.

---



### 9.1 Explanation of the function keys

---

**Key functions from the **Load** and the extensive indication are:**

-  Central Heating program key, see chapter 10.1;
-  Hot Water program key, see chapter 10.2;
-  PC program key, adjusts the pump to continuous water circulation in the central heating system, or according to the pump overrun times on the relevant programs;
- Step key, after briefly pressing, the water pressure can be retrieved and pages per chapter can be retrieved. After pressing for 5 seconds it switches from **Load** indication to technical indication and the other way round;
- Mode key, after briefly pressing, a selection of the data chapters can be retrieved. After pressing for 5 seconds it is possible to enter the code as described in chapter 10.3;
- Reset key, after briefly pressing, for:
  - unlocking errors;
  - ending the access code;
  - ending the automatic venting program, only when the access code is entered and the reset key is pressed briefly.After pressing for 5 seconds an operating stop is made, for example, for activating the automatic venting program.

**Other key functions from the other indications are:**

-  Central Heating key then has the + function;
-  Hot Water key then has the - function;
-  PC key then has the store function, which means that by means of this key a modified setting is confirmed;
- Step key for scrolling in a data chapter.



---

## 10 Filling and venting the boiler and installation

---

Filling of the system is carried out in the normal way. In order to read out the central heating water pressure the electrical supply must be switched on.

The circulation pump will not begin to operate as long as the operating lamps are off. The control display will show a **FILL** indication, which means that the control is signalling insufficient water pressure. If the installation is filled and the water pressure rises then the water pressure will automatically be shown with an alternating **FILL** text. If the water pressure rises to above 1.5 bar then after a short "stop" text the **Good** indication will appear, which means the water pressure is sufficient and the boiler is ready for operation.

In order to be able to read out a constant water pressure the Step key should be pressed in and in order to obtain a constant **Good** readout the Step key should be pressed briefly again.

If the water pressure in the boiler becomes too high (>2,8 bar) a **HIGH** text appears, by which means the burner is switched off. After draining the water from the installation, by which means the water pressure arrives below 2,5 bar, the **HIGH** text disappears and the burner is activated.

In order to go from a **Good** read-out to a technical **0 19** readout the Step key should be pressed for 5 seconds. This read-out can be selected if the user requires a technical read out. In order to return to the **Good** read-out the Step key must be pressed again for 5 seconds.

---

### 10.1 Central heating system

---

To fill the central heating system use the filling and drain valve provided.

Fill the system as follows.

- Turn on the electrical supply and leave the operational lamps off;
- Connect the filling hose to the cold water tap and let it fill with water;
- Connect the filled filling hose to the filling and draining valve and open this valve;
- Open the cold water tap and fill the installation slowly;
- The boiler has an automatic vent which removes the air which is present;
- Start venting the radiators and pipes at the lowest point;
- Bring the installation to pressure (1.5 to 2 bar) after all radiators and pipes have been vented;
- Close the cold water tap and the filling and draining valve;

- Activate the automatic venting program by pressing the pump  key which means the pump lamp will be illuminated. Allow the control to finish its venting program. The pump will circulate a number of times around the boiler as well as the central heating installation.

Also, if a three-way valve, if present, this will be adjusted to the boiler and central heating installation a number of times. The pump will be stopped regularly in order to allow possible present air to escape.

- Check the water pressure and if required top up. The working pressure in the installation should be between 1.5 and 2 bar in cold state.
- After finishing the automatic venting program the key  can be switched off again.



**It can take a while before all air has disappeared from a filled installation. Especially in the first week noises can be heard which indicate the presence of air. The automatic air vent in the boiler will make this air disappear, by which means the water pressure can reduce during this period and therefore topping up with water will have to be done.**

---

### 10.2 Hot water supply

---

Apply the water pipe pressure to the cylinder (open main valve and/or stop valve of the safety group).

Vent the cylinder and the hot water installation by opening a hot water tap. Leave the tap open for as long as required until all air has disappeared from the cylinder and the pipes and only water is flowing from the tap.

---

## 11 Commissioning the boiler

---

Before the boiler is fired, ensure that the boiler and the system are well vented and free of air. Purge the gas line between the gas meter and the boiler and carry out a gas soundness test as specified in the current Gas Safety Regulations.

The boiler does not require adjustment of the burner pressure and air quantity because it is self adjusting and is factory set at the correct value.

---

### 11.1 Central Heating system

---

Provided there is a heat requirement from the thermostat or control, the central heating program will be put into operation by means of the  key (central heating program). The circulation pump will start circulating and the boiler will start the burner.

---

### 11.2 Hot water supply

---

Provided there is a heat requirement from the cylinder the hot water program will be put into operation by means of the  key (hot water program).

---

### 11.3 Adjustments



---

In the Control Tower a number of adjustments can be made. These adjustments can be fed in easily by means of the keys on the boiler. However, a distinction is made between adjustments which are done by the user and adjustments done by the installer.

At users level adjustments can only be made from the technical read-out in other words from the display read-out with the operating function and the water temperature. Adjustments can not be made from the  indication.

The next two chapters are accessible after pressing the Mode key:

Chapter 1 

The normal operating functions such as the simple  read out or the technical  with the  read out.

Chapter 2 

The chapter in which adjustments can be made.

User parameter adjustments			
Step	description	factory	range
1	maximum flow water temp. central heating	85°C	20 - 90°C
2	type of central heating system	01	1 - 4
01	radiators; air heating; convectors		
	T max flow water	85°C	autom.
	K factor heating line	2.3	autom.
	gradient	5°C/min	autom.
	gear differential	6°C	autom.
02	radiators with large surface areas or underfloor heating as additional heating		
	T max flow water	70°C	autom.
	K factor heating line	1.8	autom.
	gradient	5°C/min	autom.
	gear differential	5°C	autom.
03	underfloor heating with radiators as additional heating		
	T max flow water	60°C	autom.
	K factor heating line	1.5	autom.
	gradient	4°C/min	autom.
	gear differential	4°C	autom.
04	full underfloor heating		
	T max flow water	50°C	autom.
	K factor heating line	1.0	autom.
	gradient	3°C/min	autom.
	gear differential	3°C	autom.
10*	fine adjustment heating line day temperature	0	-5 tot 5
11*	fine adjustment heating line night temperature	0	-5 tot 5
23	frost safety temperature	-3°C	-20 tot 10°C
31	switch-off temperature of additional cylinder with S-HR boiler	63°C	40 - 80°C
48	minimum pump capacity (S-HR 51/60)	25%(50%)	25-100%

\* See **ATAG Brain thermostat**

user adjustment possibilities

table 7

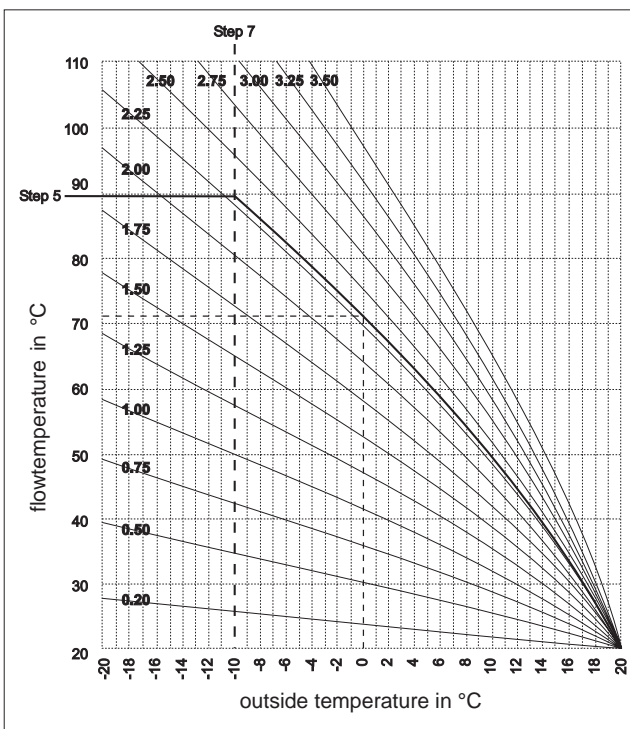

heating line settings

graph 2

### User adjustments

To switch from the **Load** level to the operating status level with the read out of the operating functions **0 49**, the water temperature and the water pressure **P 1.9**, the following acts must be carried out. From the display read-out, press the Step key for 5 seconds after which the operating status and the water temperature will be shown for 8 seconds and the water pressure for 2 seconds. If, after this, the Mode key is pressed briefly the "adjustments" chapter is displayed by means of the text **PARA**. By pressing the Step key briefly the adjustment facilities are shown. Adjustment of the fixed value can be made by means of the '+' or the '-' key. Confirmation of the new setting is done with the Store key.

### \* ATAG Brain thermostat

Most of the adjustments which are stated in tables 7 and 8 are unnecessary when in combination with the Brain and will be taken care of by the Brain itself and do not have to be adjusted. Most of the data in table 8 can be requested by the Brain. For further information with regard to the Brain thermostat we refer to the Brain thermostat installation manual.

In order to gain access to the adjustments at installers level the entrance code has to be fed in first. For this the following operations have to be carried out.

Press the Mode key for 5 seconds. The text **CODE** is shown, after which a random number appears on the display. By means of the + or the - key the code **123** can be fed in. After pressing the Store key the code is confirmed. With this code the installers level can be accessed.

The next chapters are shown after pressing the Mode key:

Chapter 3 **INFO**

The chapter where information can be retrieved.

Chapter 4 **SERV**

The chapter in which adjustments can be made for service purposes.

Chapter 5 **ERR**

The chapter in which error data can be retrieved.

### Installers adjustments

Adjustments whereby technical knowledge is required have been classified under the installers level. Access to this level is obtained after feeding in a code, after which adjustments for user and installer are visible. For going to the "Adjustments Parameters" chapter the Mode key should be pressed once after which it is shown with the **PARA** text. Scrolling in the parameter chapter can be carried out by means of the Step key. Adjusting the fixed value can be undertaken by means of the "+" or "-" key. To confirm the new adjustments press the Store key.

Extra parameter adjustments installer			
Step	description	factory	range
3	max power central heating in kW	maximum	min-max
4*	control principle with on/off thermostat	0	0 - 1
0	100% on/off thermostat		
1	100% on/off weather dependent		
5*	heating line K factor	2.3	0.2 - 3.5
6*	heating line exponent	1.4	1.1 - 1.4
7*	heating line climate zone	-10	-20 - 0
14*	gradient speed	7	0 - 15
15*	booster after night reduction	0	0 of 1
0	no		
1	yes		
36	type of three-way valve	0	0 - 3
0	VC 2010		
1	VC 6940 modulating		
43	max power power hot water in kW	maximum	min - max
49	max pump capacity central heating	100%	40 - 100%
89	address setting interface	0	-1 - 7
-1	spare		
0	Brain		
0-7	boiler 1 - 8 in Cascade		

\* See **ATAG Brain thermostat** on page 19

installer adjustment possibilities

table 8

### Information chapter.

After feeding in the access code the information can be read out according to table 9. In order to select the information chapter the Mode key must be pressed twice after feeding in the code. New adjustments can not be made in this chapter. Scrolling in the information chapter is possible by means of the Step key.

Information mode installer		
Step	description	value
1	flow water temperature T1	°C
4	return water temperature T2	°C
5	calorifier water temperature T3	°C
7	outside temperature T4	°C
8	flue gas temperature T5	°C
16	present power in %	%
17	present power in kW	kW
18	present load in kW	kW
20	control bus communication	
21	GJ consumption total	GJ
22	GJ consumption central heating	GJ
23	GJ consumption hot water	GJ
24	total number of burner run hours	hour
25	number of burner run hours central heating	hour
26	number of burner run hours hot water	hour
32	total number of hours counter	hour
46	within how many hours is service required	hour

installer information possibilities

table 9

### Service chapter.

After the access code has been fed in it is possible to temporarily manually adjust the number of revolutions of the fan in the service chapter (table 10). In order to select the service chapter the Mode key has to be pressed 3 X after feeding in the access code. By means of the Step key the first function is displayed with the text Off. By means of the + or - key a required number of revolutions for the fan can be selected while the boiler is operating.

With Step 4 it is possible to activate the showroom position by pressing the + key after which the text "on" appears in the display.

After this a simulated water pressure of 1.9 bar and a water temperature will be indicated. Pump or burner action is not possible.

Service mode installer	
Step	description
1	boiler in operation with burner function on
2	fan adjustable and burner off
3	pump adjustable with burner on
4	showroom position ON = active and OFF = non active

installer service possibilities

table 10

### Error chapter.

After the access code has been fed in the Error chapter can be read (table 11). In order to select the Error chapter it is necessary to press the Mode key 4 X after feeding in the access code. By means of the Step key the functions are shown which were stored when the boiler went into an error state. The first error which is shown is the last, the next error is the second last, etc.

In order to return to the normal technical read out whereby the water temperature and water pressure are shown, the Standby chapter must be requested by means of the Mode key. After a few seconds the text standby will be replaced by the technical read-out.

Other wise returning to the "Good" read-out automatically occurs after 20 minutes in the event that no more keys have been used.

Error mode installer		
Step	description	value
1	error number	
2	operating status unit	
3	flow water temperature T1	°C
4	return water temperature T2	°C
5	load	kW
6	pump capacity	%

installer error possibilities

table 11

### Green key function

The green key function can be used in order to activate the factory settings. By this means the modified settings are cancelled. The following actions must be carried out. Make sure that chapter **PARA** is shown in the display by means of the Mode key. After this press the Store key. The word Copy becomes visible and the factory settings will be active again.

---

## 12 Isolating the boiler

---

In some situations it may be that the entire boiler must be switched off. By switching off the three keys with the lamps for central heating, hot water and pump program, the boiler is switched off. Leave the plug in the wall socket, by which means the circulation pump and the three-way valve are activated once every 24 hours in order to prevent jamming.



**In the event of frost danger it is advisable to drain the boiler and/or the installation.**

---

## 13 Commissioning

---

The top of the casing is hooked behind a locking edge and is locked behind the door on the front of the casing with a screw. After removing this screw the casing must be lifted at the bottom by which means it is released from the locking edge. Then the casing can be removed forward.

With the S-HR settings such as burner pressure and adjustment of the air quantity are unnecessary, due to the fact that the boiler operates with a so-called zero pressure control. By this means the correct gas quantity is controlled by the suction operation of the fan. The fine adjustment which is carried out at the factory is once-only, which means that adjusting of these values is unnecessary.

---

### 13.1 Checking for contamination

---

In order to be able to check the boiler for contamination in the following running years it is advisable to measure the maximum air displacement in the boiler when putting the boiler into operation. This value can be different with each type of boiler.

In order to be able to measure this value the following operations must be carried out:

- in order to enter the service chapter feed in the access code as described on pages 19-21;
- select the manual fan setting without burner action Step **2**, by means of the Step key which will indicate that the fan is off **OFF**;

- connect the digital pressure gauge hose to the uppermost measuring nipple of the gas block according to figure 12 (open it before fitting the hose);

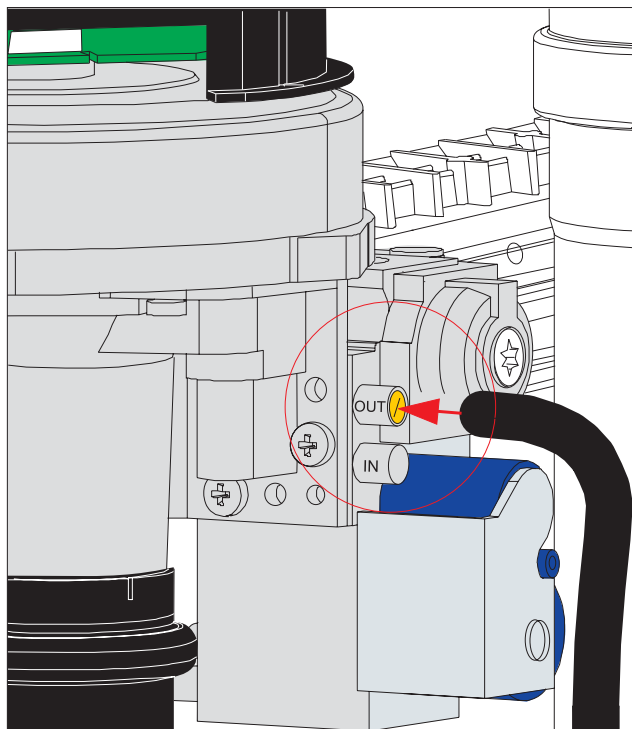

measuring point air pressure difference

figure 12

- take the fan to its maximum number of revolutions by means of the + key;
- measure the pressure difference and write down this value;
- when next servicing the boiler the value of the fan output may not have reduced by more than 20% compared to the value during commissioning. If this value is lower than 20% the boiler does not require maintenance.

---

### 13.2 Checking of the zero pressure control

---

The zero pressure control is set at the factory. This can be checked by means of the following action;

- make sure that the boiler is in operation and that it can discharge the heat which it produces;
- in order to enter the service chapter feed in the access code as described on page 21;
- select the manual fan adjustment with burner action Step **7** by means of the Step key, which will indicate that the manual operation is off **OFF**;

- connect the digital pressure gauge hose to the uppermost measuring nipple of the gas block according to figure 13;
- activate the manual control by briefly pressing the “-” key;
- take the fan to minimum load by means of the “-” key, after which the measured pressure difference must be between 0 and -4 Pa ;
- ending the manual selection is done by pressing the “-” key until the minimum load is displayed. After pressing this key again the text **OFF** is shown which means that the manual selection is off.

If it is determined that the zero pressure control deviates too much, then it can be corrected by means of the adjustment screw on the gas block.

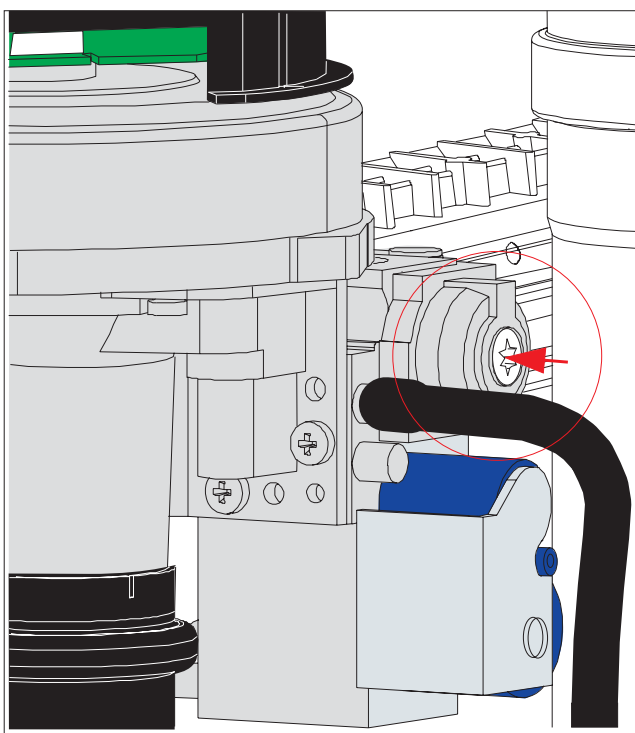

adjustment screw zero pressure control

figure 13

### 13.3 Checking the CO<sub>2</sub>

The CO<sub>2</sub> percentage is factory-set. This can be checked by means of the following actions:

- put the boiler into operation by means of the service chapter as described in chapter 11.2;
- place the lance of the CO<sub>2</sub> gauge in the location according to figure 14;

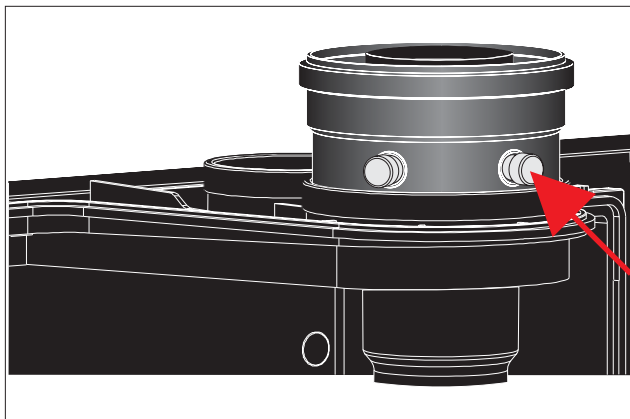

measuring point for CO<sub>2</sub>

figure 14

- adjust to maximum load by means of the “+” key;
- ending the manual selection is done by pressing the “-” key until the minimum load is shown. After pressing this key again the text **OFF** is shown which means that the selection is off.
- adjust the CO<sub>2</sub> percentage according to table 12. The CO<sub>2</sub> percentage can be adjusted by means of the adjustment screw according to figure 15.

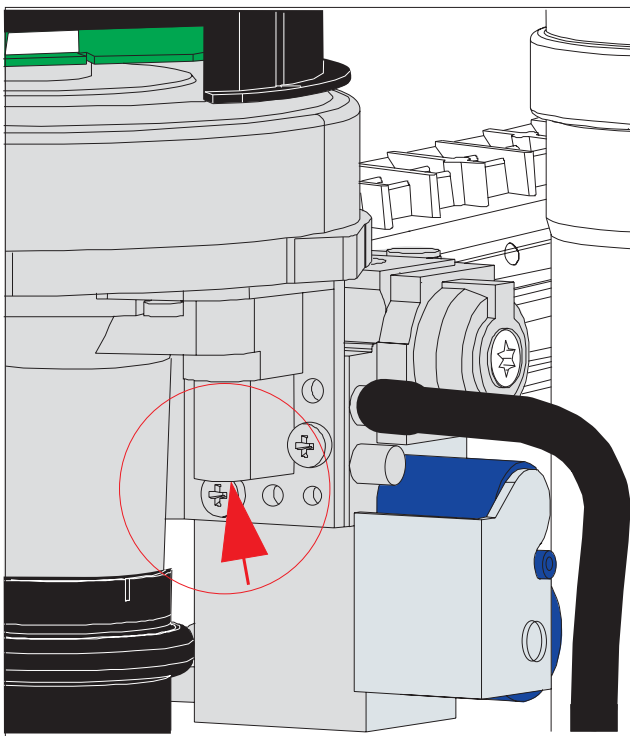

adjustment screw CO<sub>2</sub>

figure 15

---

## 14 Maintenance

---

 **Maintenance or changes to the unit may only be carried out by an authorised technician.**

### 14.1 The frequency of maintenance

---

We advise to carry out an inspection to the boiler every two years and an overhaul every four years. When doing this the circumstances of the boiler's location must be taken into account. From this one can determine whether to deviate from this advice.

### 14.2 Maintenance activities

---

If it is necessary to clean the boiler the following actions to the following components must be carried out:

#### The air boiler

Dirt which is sucked in by the air supply pipe will end up in the bottom of the air box. This dirt can be cleaned with a cloth with a simple (non-abrasive) cleaning agent.

 **Do not use an abrasive agent for cleaning, this causes disturbing scratches in the air box.**

#### The burner ceramic bricks and heat exchanger

These components should only be cleaned if it is determined that the maximum Pa is no longer obtained as described in chapter 12.1.

The fan unit must be removed in order to be able to inspect the heat exchanger. In this case the following actions must be carried out:

- close the gas valve and isolate the boilers electrical supply;
- turn the Control Tower forward around its left hinge point and remove the plastic air box;
- loosen the nut of the gas pipe under the gas block;
- loosen the small crosshead screw on the red electrical connection adaptor of the gas block;
- remove the electrical connection plug from the fan motor;
- loosen the front crosshead screw of the black plastic air inlet damper;
- after this turn the two clamping rods ¼ turn and remove them by pulling them forward;
- slightly lift the fan unit and remove it towards the front of the heat exchanger;
- the fan unit and the air inlet damper can be checked for contamination and if necessary cleaned;
- now remove the burner ceramic bricks by slightly lifting them upward and removing them in the same direction as the heat exchanger fan unit;
- the burner ceramic bricks and the heat exchanger can be cleaned by means of a soft brush;

Refitting of the components is done in reverse.

The following components require extra attention during the service procedure and when dismantling and reassembling the burner:

- ensure that the orange gasket that fits around the ceramic brick has not heat hardened or perished in any way, if it has, it is essential that the gasket is replaced before continuing to reassemble the boiler. If in any doubt replace the gasket;
- make sure that the burner gasket is fitted onto the heat exchanger precisely;
- make sure that the fan unit clamping rods have been pushed backward sufficiently and that they have again been turned ¼ turn;
- make sure that the gas connection under the gas block is tightened;

 **Following maintenance or other activities; always check the installation of all parts through which gas flows (using leak-search spray).**

#### The siphon

In order to check the siphon for contamination the following actions must be carried out:

- make sure that the boiler is off by isolating the boilers electrical supply;
- turn the Control Tower forward around its left hinge point;
- turn the siphon cup to the left until it is released from the screw thread;

 **Do not use pliers or wrenches for removing the siphon cup**

Refitting is done in reverse order.

### 14.3 Further checks

---

Checking the ionisation current.

- ionisation determines if there is a flame present with correct combustion. The measurement is done by means of connecting a micro Ampere gauge in series with the ionisation thread. The minimum allowed ionisation is 2 µA. The boiler will modify its load anyway if the ionisation reaches the bottom limit of 2 µA.

Checking by means of a visual inspection.

- A visual inspection entails viewing and checking of a number of components with regard to their functioning. The safety valve may not show any traces of leaks. The waste trap should be clean. The central heating water filter only requires cleaning if the circulation pump is adjusted at maximum speed and the maximum  $\Delta T$  is exceeded.

 **Following maintenance or other activities, always replace the housing and secure it with the screws.**

 **Complete the Benchmark Service Record Log Book as required and hand back to customer.**



## 15 Technical specifications

appliance type		S-HR 15	S-HR 24	S-HR 24T	S-HR 35	S-HR 35T	S-HR 51	S-HR 51TL	S-HR 60	
input (Hs)	kW	15,0	24,0	24,0	35,0	35,0	51,0	51,0	60,0	
input (Hi)	kW	13,5	21,6	21,6	31,5	31,5	45,9	45,9	54,0	
modulation range (capacity 80/60°C)	kW	3,5-13,3	3,5-21,2	3,5-21,2	4,9-30,9	4,9-30,9	8,8-44,9	8,8-44,9	8,8-52,9	
modulation range (capacity 50/30°C)	kW	3,9-14,4	3,9-23,0	3,9-23,0	5,3-33,6	5,3-33,6	9,5-48,7	9,5-48,7	9,5-57,2	
efficiency (80/60°C at full load)	%	98	98	98	98	98	98	98	98	
efficiency (50/30°C at full load)	%	107	107	107	107	107	106	106	106	
efficiency in accordance with EN677	%	109	109	109	109	109	109	109	109	
yearly emission of NOx	ppm	12	12	12	12	12	12	12	12	
yearly emission of CO	ppm	11	11	11	11	11	11	11	11	
CO <sub>2</sub> (G20)	%	9	9	9	9	9	9,5	9,5	9,5	
flue gas temperature (at 80/60°C at full load)	°C	65	65	65	67	67	68	68	68	
flue gas temperature (at 50/30°C at low load)	°C	31	31	31	31	31	31	31	31	
burner control		stepless modulation								
gas consumption (at 1013 mbar/0°C) G20	m <sup>3</sup> /h	1,32	2,10	2,10	3,07	3,07	4,47	4,47	5,26	
burner type		ceramic					foam ceramic			
current type	V/Hz	230/50	230/50	230/50	230/50	230/50	230/50	230/50	230/50	
maximum electric power recorded	W	92	92	92	115	115	212	212	212	
standby electric power recorded	W	5	5	5	5	5	5	5	5	
degree of protection according to EN60529		IP 40	IP 40	IP 40	IP 40	IP 40	IP 40	IP 40	IP 40	
weight (net)	kg	50	50	73	53	76	63	86	63	
water capacity CH-based	l	3,5	3,5	3,5	5	5	7	7	7	
water capacity DHW-based	l			14		14		13		
pump overrun time CH	min	15	15	15	15	15	15	15	15	
pump overrun time DHW	min			1		1		1		
minimum water pressure	bar	1	1	1	1	1	1	1	1	
maximum water pressure	bar	3	3	3	3	3	3	3	3	
maximum flow water temperature	°C	90	90	90	90	90	90	90	90	
DHW flow rate at 60°C	l/min			6		8,5		12,5		
DHW flow rate at 45°C	l/min			8,5		12,5		17,5		
pump type	Grundfos	UPER 20-60	UPER 20-60	UPER 20-60	UPER 20-60	UPER 20-60	UPER 20-70	UPER 20-70	UPER 20-70	
available pump head	kPa	42	30	30	20	20	25	25	20	
expansion vessel content	l			12		12				
expansion vessel pre-charge pressure	bar			1		1				
appliance type		S-HR 15 P	S-HR 24 P	S-HR 24T P	S-HR 35 P	S-HR 35T P	S-HR 51 P	S-HR 51TL P	S-HR 60 P	
input (Hs)	kW	15,0	24,0	24,0	35,0	35,0	51,0	51,0	60,0	
input (Hi)	kW	13,8	22,1	22,1	32,2	32,2	46,9	46,9	55,2	
modulation range (capacity 80/60°C)	kW	9,6-13,3	9,6-21,2		15,2-30,9		19,2-44,9		19,2-52,9	
modulation range (capacity 50/30°C)	kW	10,4-14,4	10,4-23,0		16,5-33,6		20,9-48,7		20,9-57,2	
CO <sub>2</sub> (LPG)	%	10,5	10,5	10,5	10,5	10,5	10,5	10,5	10,5	
gas consumption(LPG)	kg/h	1,0	1,7	1,7	2,4	2,4	3,7	3,7	4,2	
gas consumption(LPG)	m <sup>3</sup> /h	0,5	0,8	0,8	1,2	1,2	1,8	1,8	2,1	
Gas inlet working pressure	mbar	30	30	30	30	30	30	30	30	

boiler specifications

table 12

## 16 Diagram showing various parts of the boiler

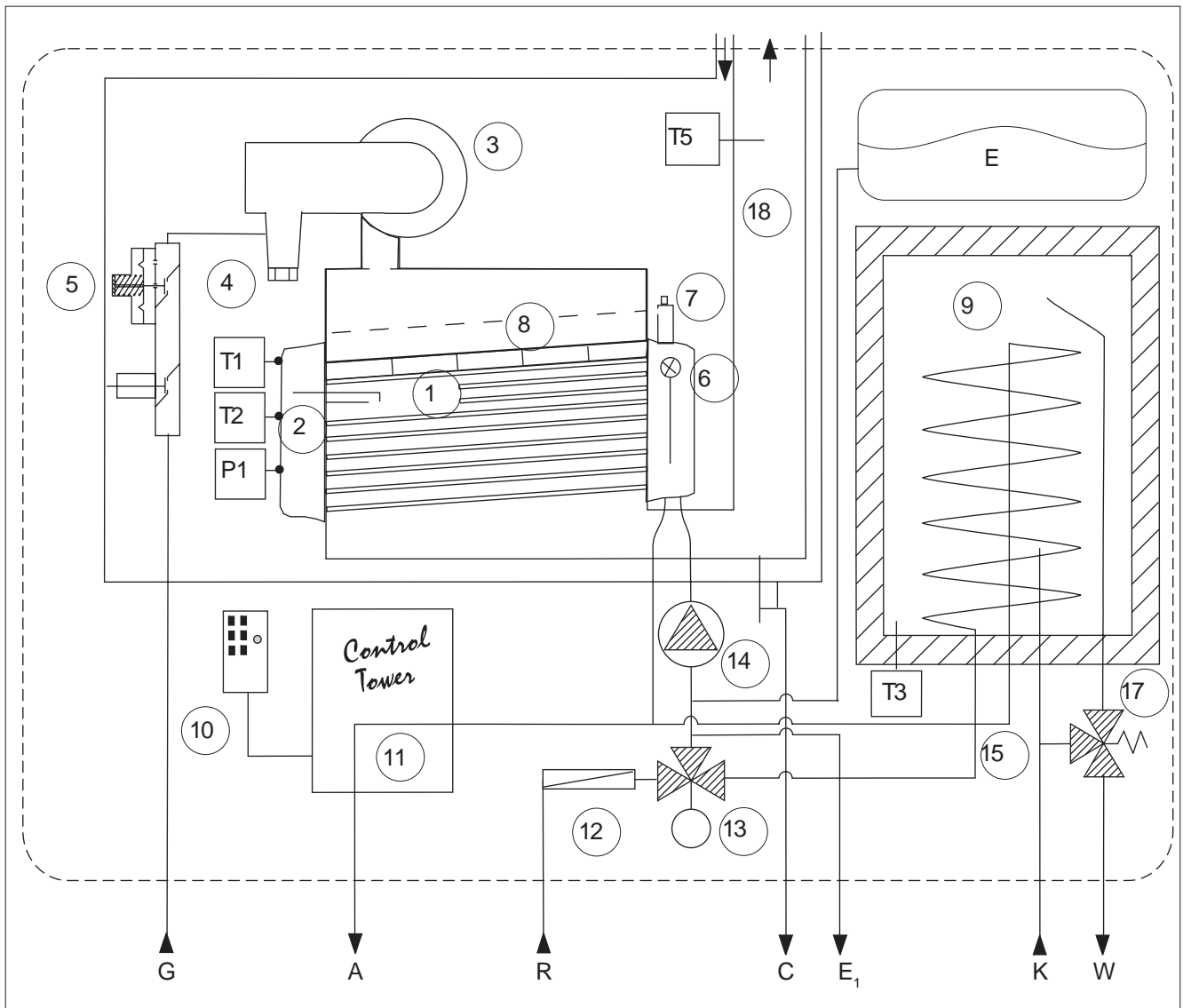

boiler diagram

figure 16

- G gas pipe
- A flow connection central heating
- R return connection central heating
- C condensation pipe
- E expansion vessel (only S-HR 24T and 35T)
- E<sub>1</sub> expansion vessel pipe (only S-HR 51T)
- K cold water pipe (S-HR-T)
- W hot water pipe (S-HR-T)

- T1 flow sensor
- T2 return sensor
- T3 cylinder sensor HWS (S-HR-T)
- T5 flue gas sensor (if fitted)

- P1 water pressure sensor

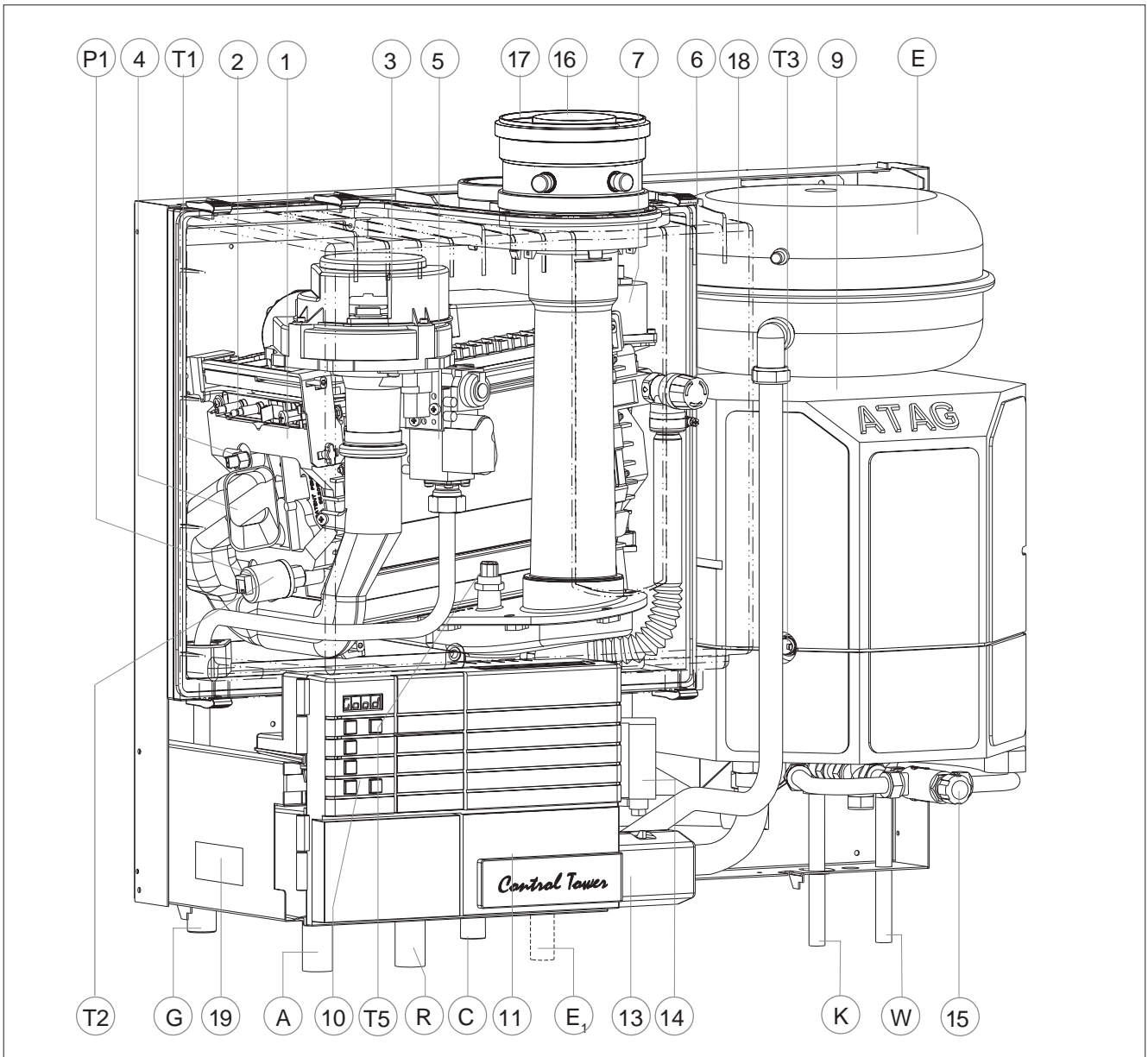

boiler description

figure 17

- |    |                       |    |                                     |
|----|-----------------------|----|-------------------------------------|
| 1  | heat exchanger        | 11 | Control Tower                       |
| 2  | ignition unit         | 12 | water filter return central heating |
| 3  | fan unit              | 13 | three-way valve (S-HR-T)            |
| 4  | air inlet damper      | 14 | circulation pump                    |
| 5  | gas block             | 15 | thermostatic mixing valve (S-HR-T)  |
| 6  | safety valve          | 16 | flue gas discharge                  |
| 7  | automatic air vent    | 17 | combustion air supply               |
| 8  | ceramic burner bricks | 18 | air unit                            |
| 9  | cylinder HWS (S-HR-T) | 19 | type plate                          |
| 10 | operating panel       |    |                                     |

## 17 Example diagrams for connecting the boiler

### 17.1 Radiator installation without thermostat valves

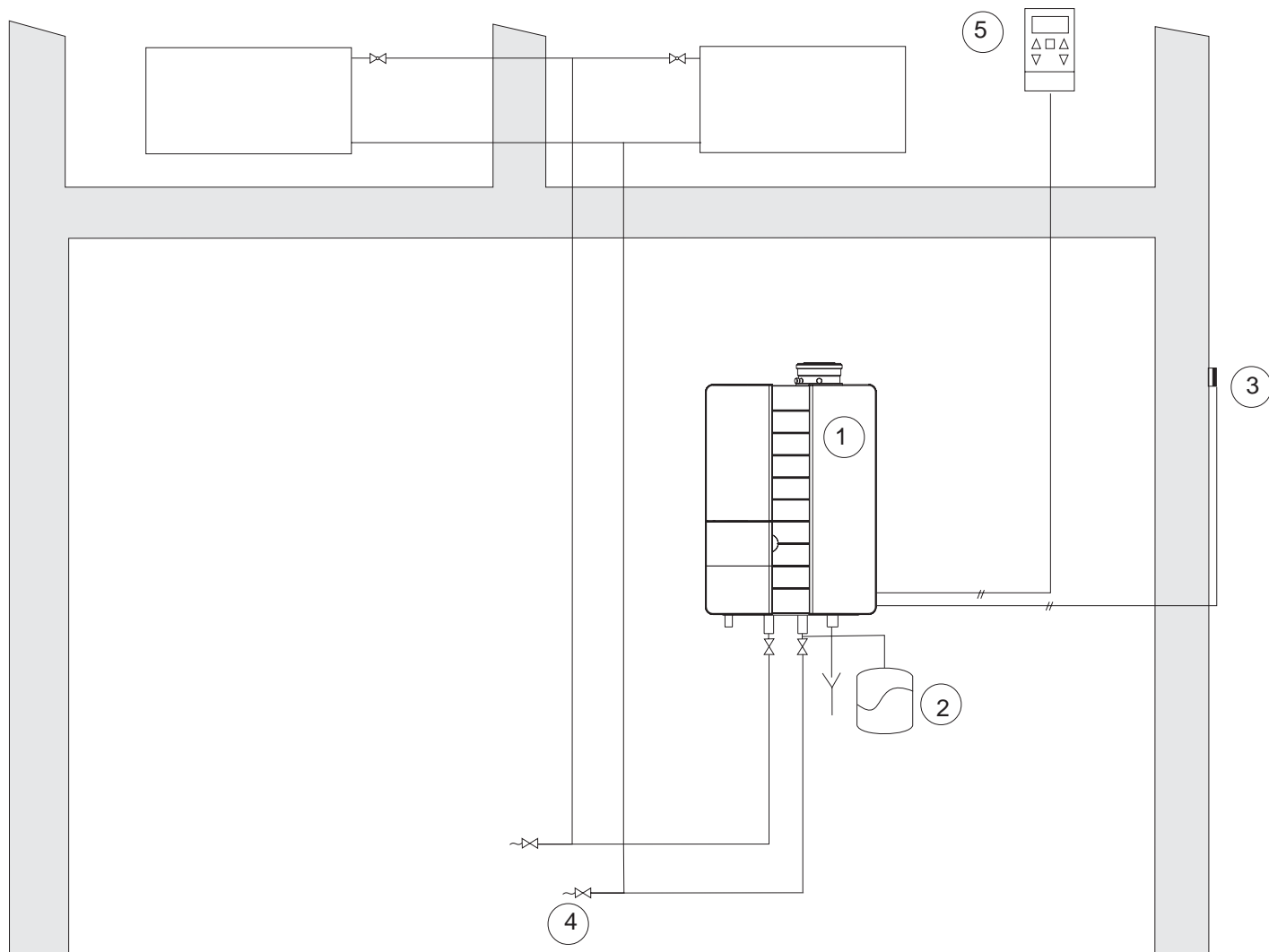

connecting of the boiler to a radiator installation without thermostat valves

figure 18

- 1 ATAG Blauwe Engel S-HR boiler
- 2 expansion vessel
- 3 outside sensor ARV1215U
- 4 drain points
- 5 ATAG room thermostat

## 17.2 radiator installation with thermostat valves only

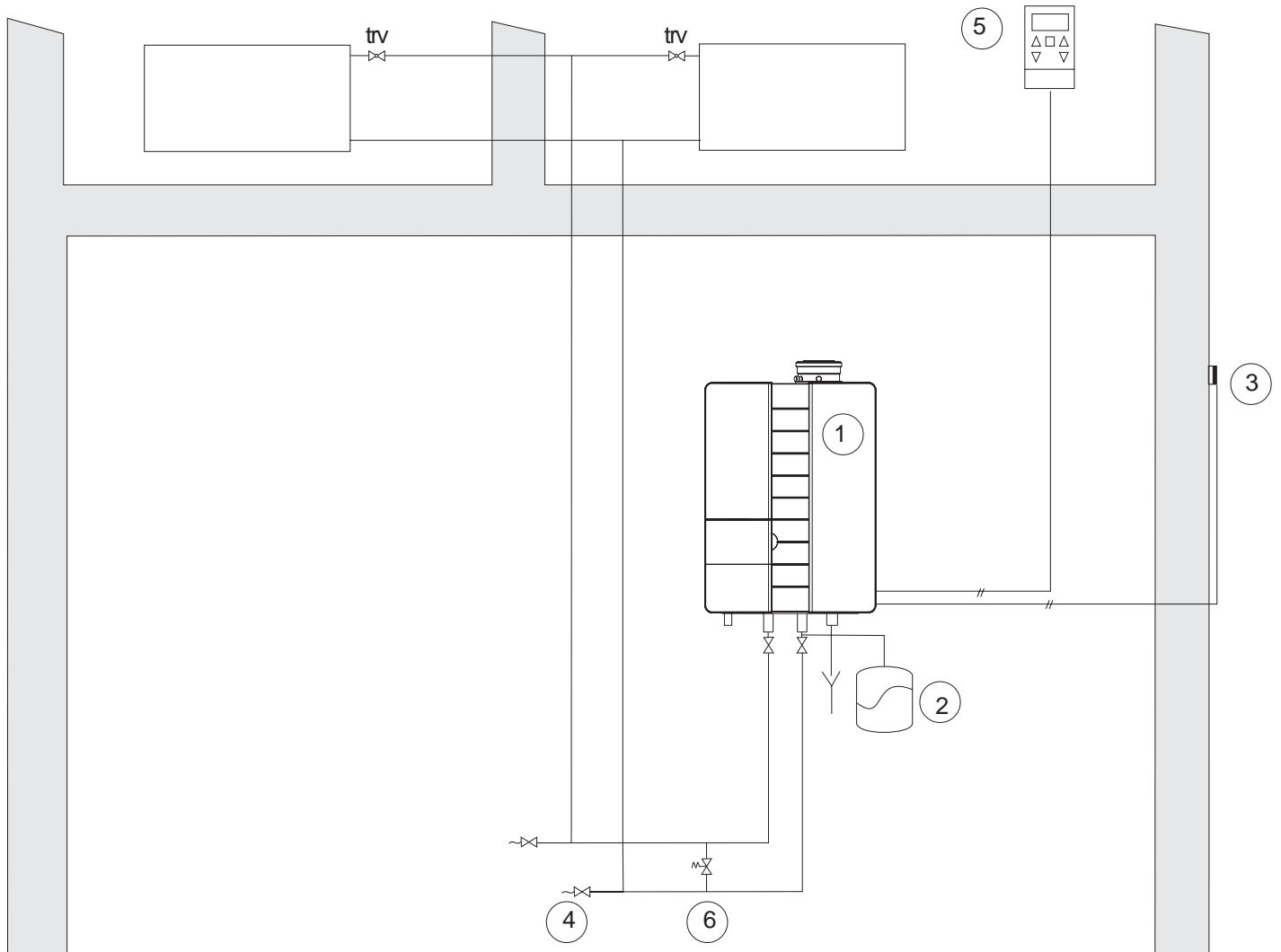

connecting of the boiler to a radiator installation with thermostat valves only

figure 19

- 1 ATAG Blauwe Engel S-HR boiler
- 2 expansion vessel
- 3 outside sensor ARV1215U
- 4 drain points
- 5 ATAG room thermostat
- 6 by-pass

trv thermostatic radiator valve

---

## 18 Error indication

---

When detected, errors are indicated on the display. Some, of a temporary nature, will not usually result in the boiler locking out. Whilst the control system will try its utmost to prevent lockout, and may temporarily switch off the unit, any fault which could potentially damage the appliance will result in lockout. The following are examples of message display, which fall into two categories - i.e. Blocks and Errors.

Blocks **bL** with a number in the last 2 positions.

- bL01** Block 01:  
External safety contact cut out
- bL11** Block 11:  
Maximum  $\Delta T$  of flow and return sensor in central heating has repeatedly been exceeded. During the block normal operation of the hot water supply is possible. The pump continues to operate at minimum capacity during the block.
- bL12** Block 12:  
Maximum  $\Delta T$  of flow and return sensor in domestic hot water has repeatedly been exceeded. During the block normal operation of the central heating installation is possible. During the block the pump continues to operate at minimum capacity.
- bL60** Block 60:  
Incorrect parameter setting of the minimum or maximum power.
- bL67** Block 67:  
A  $\Delta T$  has been detected between flow and return sensor whereas the burner is not in operation. After the  $\Delta T$  has disappeared the block will disappear.
- bL80** Block 80:  
Maximum flue gas temperature has been exceeded (if present). The block will not be cancelled until the flue gas temperature has arrived below the temperature.
- bL81** Block 81:  
The flue gas sensor is not connected although it has been connected to the control. The burner is blocked until the flue gas sensor is reconnected.
- bL82** Block 82:  
The flue gas sensor has short-circuited, heat requirement blocked and pump capacity at minimum.
- bL85** Block 85:  
The control has not detected a water flow. The venting cycle is started. If during this cycle water flow is detected, the venting cycle is ended and the burner is released.

Error **E** with a number in the last two positions.

- E 00** Error 00: poor flame-forming
- E 01** Error 01: short-circuit of 24 volt circuit
- E 02** Error 02: no flame-forming
- E 03** Error 03: temperature in airbox too high
- E 04** Error 04: adjustment or error for voltage interruption
- E 05** Error 05: fault control unit
- E 12** Error 12: fuse 24 volt/3AT faulty
- E 19** Error 19: maximum return temperature exceeded
- E 28** Error 28: number of revolutions not reported back from fan

Number E 0430



GASTEC Certification B.V. hereby declares that the **condensing boilers, ATAG, types**

S-HR15(P)      S-HR24(P)      S-HR35(P)      S-HR51L(P)      S-HR60(P)  
S-HR15H60(P)      S-HR24T(P)      S-HR35T(P)      S-HR51TL(P)

made by            **ATAG Verwarming Nederland B.V.,**  
in                    **Lichtenvoorde, The Netherlands,**

marketed by       **ATAG Heating UK Ltd,**  
in                    **West Sussex, United Kingdom,**

meet the essential requirements as described in the **Directive on appliances burning gaseous fuels (90/396/EEC)**, and in the **Directive on efficiency requirements (92/42/EEC)**.

PIN                    : 0063AS3538  
Report number      : 170538  
Appliance types    : B<sub>23</sub>, B<sub>33</sub>, C<sub>13</sub>, C<sub>33</sub>, C<sub>43</sub>, C<sub>53</sub>, C<sub>63</sub>, C<sub>83</sub>

Mentioned products have been approved for:  
GB I<sub>2H</sub>, I<sub>3P</sub>, II<sub>2H3P</sub>

Apeldoorn, 25 June 2003

Ir. M.L.D. van Rij,  
General manager.

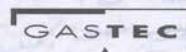

GASTEC Certification B.V.  
P.O. Box 137  
7300 AC Apeldoorn  
The Netherlands  
Wilmerdorff 50  
7327 AC Apeldoorn



CERTIFICATE

Number E 0430



CERTIFICATE

GASTEC Certification B.V. hereby declares that the **condensing boilers, ATAG, types**

S-HR15(P)	S-HR24(P)	S-HR35(P)	S-HR51L(P)	S-HR60(P)
S-HR15H60(P)	S-HR24T(P)	S-HR35T(P)	S-HR51TL(P)	

made by **ATAG Verwarming Nederland B.V.,**  
in **Lichtenvoorde, The Netherlands,**

marketed by **Total Energy Management Ltd.,**  
in **Co. Galway, Ireland,**

meet the essential requirements as described in the **Directive on appliances burning gaseous fuels (90/396/EEC),** and in the **Directive on efficiency requirements (92/42/EEC).**

PIN : 0063AS3538  
Report number : 170538  
Appliance types : B<sub>23</sub>, B<sub>33</sub>, C<sub>13</sub>, C<sub>33</sub>, C<sub>43</sub>, C<sub>53</sub>, C<sub>63</sub>, C<sub>83</sub>

Mentioned products have been approved for:

IE I<sub>2H</sub>, I<sub>3P</sub>, II<sub>2H3P</sub>

Apeldoorn, 25 June 2003

Ir. M.L.D. van Rij,  
General manager.



GASTEC Certification B.V.  
P.O. Box 137  
7300 AC Apeldoorn  
The Netherlands  
Wilmersdorf 50  
7327 AC Apeldoorn



03/227











**This renewed publication cancels all previous installation instructions.**  
**The company reserves the right to change the specifications and dimensions without prior notice**

## Explanations of symbols and signs on the Control Tower display.

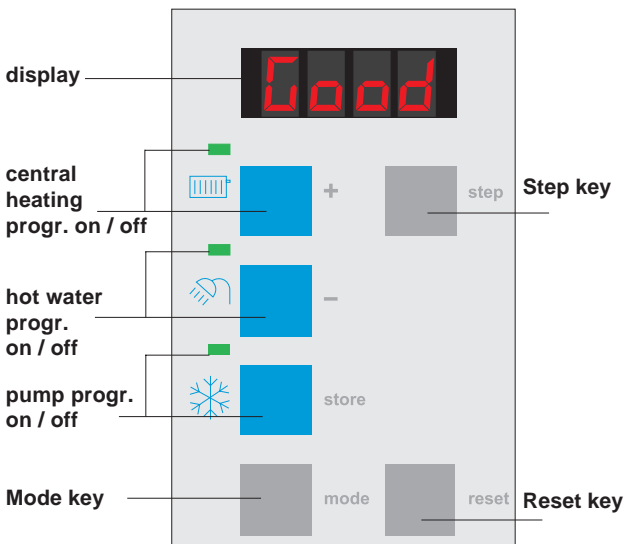

Mode key ~ Selecting chapters

Step key ~ Scrolling in a chapter

Reset key ~ Unlocking the boiler in case of error

### Operation indication (in the first display position)

- 0** No heat requirement
- 1** Ventilation phase
- 2** Ignition phase
- 3** Burner active on central heating
- 4** Burner active on hot water
- 5** Fan check
- 6** Burner off when room thermostat is demanding
- 7** Pump overrun phase for central heating
- 8** Pump overrun phase for hot water
- 9** Burner off because of too high flow water temperature
- A** Automatic venting programme



Water pressure is too low (<1,0 bar), flashing FILL will be altered with indication of water pressure, boiler power of 50% is possible. The installation needs to be topped up.



Water pressure is too low (<0,7 bar), FILL indication remains continuously visible, the boiler is taken out of operation. The installation needs to be topped up.



Water pressure is too high (>2,8 bar), HIGH indication remains continuously visible, the boiler is taken out of operation. The installation pressure needs to be decreased by draining water.

### Distributor for UK

ATAG Heating UK Ltd.  
Unit M1  
Hilton Business Park  
East Wittering  
West Sussex PO20 8RL

Phone: 01243 673888

Fax: 01243 673444

Email: [info@atagheating.co.uk](mailto:info@atagheating.co.uk)

Internet: [www.atagheating.co.uk](http://www.atagheating.co.uk)

### Distributor for Ireland

Total Energy Management Ltd.  
Unit 9, Ballybritt Industrial Estate,  
Monivea Road,  
Galway, Ireland.

Tel.: (091) 769174

Fax: (091) 769485

Email: [info@tem.ie](mailto:info@tem.ie)

Internet: [www.tem.ie](http://www.tem.ie)