



Protherm 100 e

Note: The boiler serial number is marked on the data label attached to the fascia behind the front panel. Refer to the 'Introduction' section for a description of the basic functions of the boiler. The 'User' section describes how to safely operate the boiler.

Users' Instructions

- Introduction 2
- Controls and lighting 2
- Draining and filling 3
- Heating safety valve 3
- Servicing/maintenance 3
- Cleaning 3
- Boiler casing 3

Installation Instructions

- Introduction 4
- Technical data 5
- Dimensions 6
- Pump capacity 6
- Boiler schematic 7
- Installation section 8
- Terminal positions 8
- Heating and hot water system design 9
- Boiler installation 10
- Horizontal flue installation 12
- Vertical flue installation 13
- Flue configurations 14
- Electrical connection 15
- Commissioning 16

Servicing Instructions

- Routine cleaning and inspection 18
- Replacement of parts 19
- Schematic wiring diagram 22
- Fault finding 23
- Conversion to LPG 24

Mandatory warning for CE countries

WARNING, these appliances were designed, approved and inspected to meet the requirements of the English market. The identification plate located on the inside of the appliance **certifies the origin** where the product was manufactured and the **country** for which it is intended.

If you see any exception to this rule, please contact your nearest stockist.

Thank you in advance for your assistance.

USERS INSTRUCTIONS

PLEASE VISIT WWW.HEATINGSARES247.COM FOR FURTHER INFORMATION AND GENUINE PARTS & SPARES AT LOW PRICES

The **Protherm 100 e** is a wall mounted combination boiler providing central heating and instantaneous domestic hot water.

These instructions should be carefully followed for the safe and economical use of your boiler.

Gas leak or fault

If a gas leak or fault exists or is suspected, turn the boiler and gas supply off and consult the local gas company or your Installer/Service provider.

In case of power supply failure

The boiler no longer operates.

As soon as power supply is restored, the boiler will restart automatically.

In case of loss of water in the system

CAUTION: The boiler is installed as part of a sealed system which must only be drained and filled by a competent person.

If the pressure shown on the pressure gauge is less than 1 bar the system must be filled up immediately.

Important notice: A central heating system cannot operate satisfactorily unless it is properly filled with water and unless the air initially contained in the piping systems has been properly bled off. If these conditions are not satisfied, air noise will occur within the system and the boiler may fail to operate.

Air in the heating system

Persistent air in the heating system may indicate leaks in the system or corrosion taking place. Call your Installer/Service provider.

Overheating safety

In the event of problem, the overheat safety device causes safety shutdown of the boiler. If this happens, call your Installer/Service provider.

CONTROLS AND LIGHTING

The control panel is located behind the drop down front door. The controls on this panel allow the boiler to be started, shut down, controlled and monitored during use, see diagram 1.

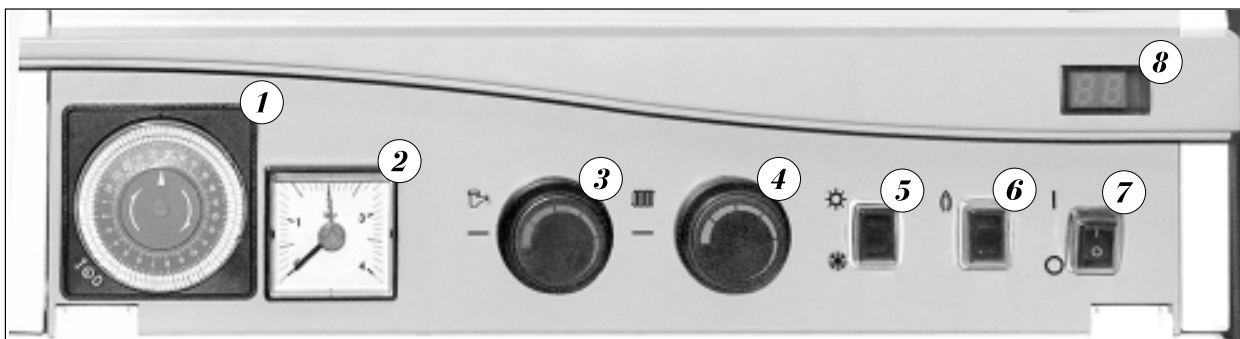

Diagram 1

Controls

- | | |
|-----------------------------------|--------------------------|
| 1 - Timeclock | 5 - Summer/Winter switch |
| 2 - Pressure gauge | 6 - Reset button |
| 3 - Hot water temperature control | 7 - Mains On/Off switch |
| 4 - Heating temperature control | 8 - Digital display |

Make sure that:

- The boiler is connected to the electrical supply.
- The boiler gas service cock is open.
- The pressure gauge reads between 1 and 2 bar.

The boiler is now ready to start.

To start the boiler

- Place switch (7) in the On position “I”
- Place switch (5) in the desired Summer ☀ or Winter ❄ position

To stop the boiler

Place switch (7) to the Off position “O”.

If the boiler is to be out of operation for a long period, turn off the gas service cock.

Setting to ‘Summer’ mode (Hot water only)

Place switch (5) in the Summer position ☀

Setting to ‘Winter’ mode (Heating and hot water)

Place switch (5) to the Winter position ❄

Adjust the heating temperature control (4) to the desired temperature.

Adjust the domestic hot water control (3) to the desired hot water temperature. The heating will operate according to the requirements of the timeclock and/or room thermostat if fitted or, will operate according to the system requirements.

Domestic hot water always has priority over central heating.

Timeclock

The boiler can be switched on and off automatically by the built-in timeclock. To set the timeclock, proceed as follows: (referring to diagram 1)

Press in the tappets corresponding to the time you want the boiler to be on.

For example if you want the boiler to be on between 7 AM and 9 AM, push in all the tappets between 7 and 9.

Set the times you want the boiler to be on for the rest of the day in the same way.

Note: The timeclock setting is in 24 hour format. Therefore, if you want the boiler to come on at 2 PM you must push in the tappets at 14.

To set the correct time rotate the clock by hand until the current time is indicated by the arrow at the top of the clock.

To operate the boiler according to your selected times, place the grey lever to the ⊕ position.

To have the boiler permanently ‘ON’, place the grey lever to the ‘I’ position.

To have the boiler permanently ‘OFF’, place the grey lever to the ‘O’ position.

Safety lockout

In the event of a safety lockout, the digital display will show ‘F1’.

Reset boiler by pressing the RESET button (6).

IMPORTANT: If safety lockout occurs frequently, or if any other fault is indicated, contact your Installer/Service Provider.

Draining and filling

CAUTION: The boiler is installed as part of a sealed system which must only be drained and filled by a competent person.

Note: If there is persistent loss of system pressure, you must consult your Installer/Service Provider.

If the pressure shown on the pressure gauge is less than 1 bar the system must be filled immediately.

Heating safety valve

CAUTION: A safety valve with a discharge pipe is fitted to this boiler.

The valve **MUST NOT BE TOUCHED** except by a competent person. If the valve discharges at any time, switch the boiler off and isolate it from the electrical supply. Contact your Installer/Service Provider.

Servicing/Maintenance

To ensure the continued efficient and safe operation of the boiler, it is recommended that it is checked and serviced at regular intervals. The frequency of servicing will depend upon the installation conditions and usage but, in general, once a year should be enough.

Cleaning

The boiler casing can be cleaned with a damp cloth followed by a dry cloth to polish.

Do not use abrasive or solvent cleaners.

Boiler casing

CAUTION: Do not remove or adjust the casing in any way, as incorrect fitting may result in faulty operation.

If in doubt, contact your Installer/Service Provider.

Introduction

The **Protherm 100 e** is a wall mounted combination boiler providing central heating and instantaneous domestic hot water.

The boiler is of the II_{2H3+} category for use with Natural gas (G20) as distributed in the United Kingdom, or with Butane or Propane gas (G30/G31) with the appropriate conversion kit.

Conversion kit:

Conversion	Part No.
Natural gas (G20) to G30/G31	92321165

Modification must only be carried out by a suitably qualified engineer.

Boilers burning LPG or similar gases MUST NOT be fitted in basements or below ground level.

These instructions should be carefully followed for the safe and economical use of your boiler.

The boiler has a fan assisted, balanced, flue which both discharges the product of combustion to, and draws the combustion air from the outside of the building.

Accessories

A range of accessories are available including, vertical flue components. For further information, contact your nearest stockist.

Gas Safety (Installation and Use) Regulations

In the interests and that of gas safety, it is the law that ALL gas appliances are installed and serviced in by a competent person in accordance with the above regulations.

Gas leak or fault

If a gas leak or fault exists or is suspected, turn the boiler and gas supply off and consult the local gas company or your Installer/Service Provider.

Boiler controls

The control panel, located at the lower front of the boiler, allows the boiler to be started, shut down, controlled and monitored during use, refer to '**Users Instructions**'.

**TECHNICAL DATA**PLEASE VISIT WWW.HEATINGSPPARES247.COM FOR FURTHER INFORMATION AND GENUINE PARTS & SPARES AT LOW PRICES**Protherm 100e**

CE Certification	n°	49 AU 2915		
Class		II _{2H3+}		
Type		C ₁₂ , C ₃₂		
Gas type		G20	G30	G31
Max. Heat Input	kW	30.5	30.5	30.5
Min. Heat Input	kW	12.1	12.1	12.1
Max. Heat Output	kW	27.4	27.4	27.4
Min. Heat Output	kW	10.0	10.0	10.0
GAS SUPPLY PRESSURE				
Burner pressure	mbar	2.1 – 15.0	3.8 – 28.8	4.1 – 36.7
Nominal pressure	mbar	20	29	37
Injectors diameter	∅ mm	1.2	0.73	0.73
GAS CONSUMPTION				
Qmax	m ³ /h	3.2	1.1	1.4
Qmin	m ³ /h	1.3	0.5	0.6
Air flow	m ³ /h	135	135	135
EFFICIENCY				
Nominal efficiency	%	89,8		
Efficiency at 30% load	%	86,7		
HEATING				
Temperature range	°C	30 - 85		
Expansion vessel	l	7		
Expansion vessel pressure	bar	1		
Max. working pressure	bar	3		
Max. system temperature	°C	85		
Max. system capacity	l	130		
HOT WATER				
Flow rate at 30°C temperature rise	l/min	13.1		
Flow rate at 35°C temperature rise	l/min	11.3		
Min. water flow	l/min	2		
Max. supply pressure	bar	6		
Min. supply pressure	bar	0.5		
Temperature range	°C	40 – 60		
ELECTRICAL DATA				
Voltage/frequency	V/Hz	~230/50		
Current	A	0.8		
Power	W	180		
Level of protection	IP	IP 44		
DIMENSIONS				
Width	mm	450		
Height	mm	880		
Depth	mm	370		
Weight	kg	42		
CONNECTIONS				
Heating flow/return	mm	22		
Domestic Water inlet/outlet	mm	15		
Gas	mm	22		
Flue products outlet/air inlet ∅	mm	horiz. 60/100 – vert. 80/125		
Horizontal flue length min/max	m	0.3 – 3		
Vertical flue length min/max	m	0.5 – 11,5		

HEAT OUTPUT		PRESSURE		
kW	Btu/hr	G20 mbar	G30 mbar	G31 mbar
10	34 120	2.1	3.8	4.1
11	37 532	2.5	4.6	5.2
12	40 944	3.0	5.5	6.4
13	44 356	3.6	6.6	7.8
14	47 768	4.2	7.7	9.2
15	51 180	4.8	9.0	10.9
16	54 592	5.4	10.3	12.6
17	58 004	6.2	11.7	14.5
18	61 416	6.8	13.2	16.4
19	64 828	7.5	14.7	18.3

HEAT OUTPUT		PRESSURE		
kW	Btu/hr	G20 mbar	G30 mbar	G31 mbar
20	68 240	8.2	16.2	20.3
21	71 652	9.0	17.7	22.3
22	75 064	9.8	19.3	24.4
23	78 478	10.7	21.0	26.6
24	81 888	11.6	22.7	28.9
25	85 300	12.6	24.5	31.2
26	88 712	13.6	26.2	33.5
27	92 124	14.7	28.1	35.8
27.4	93 489	15.0	28.8	36.7

DIMENSIONS AND PRESSURE AVAILABLE

PLEASE VISIT WWW.HEATINGSPPARES247.COM FOR FURTHER INFORMATION AND GENUINE PARTS & SPARES AT LOW PRICES

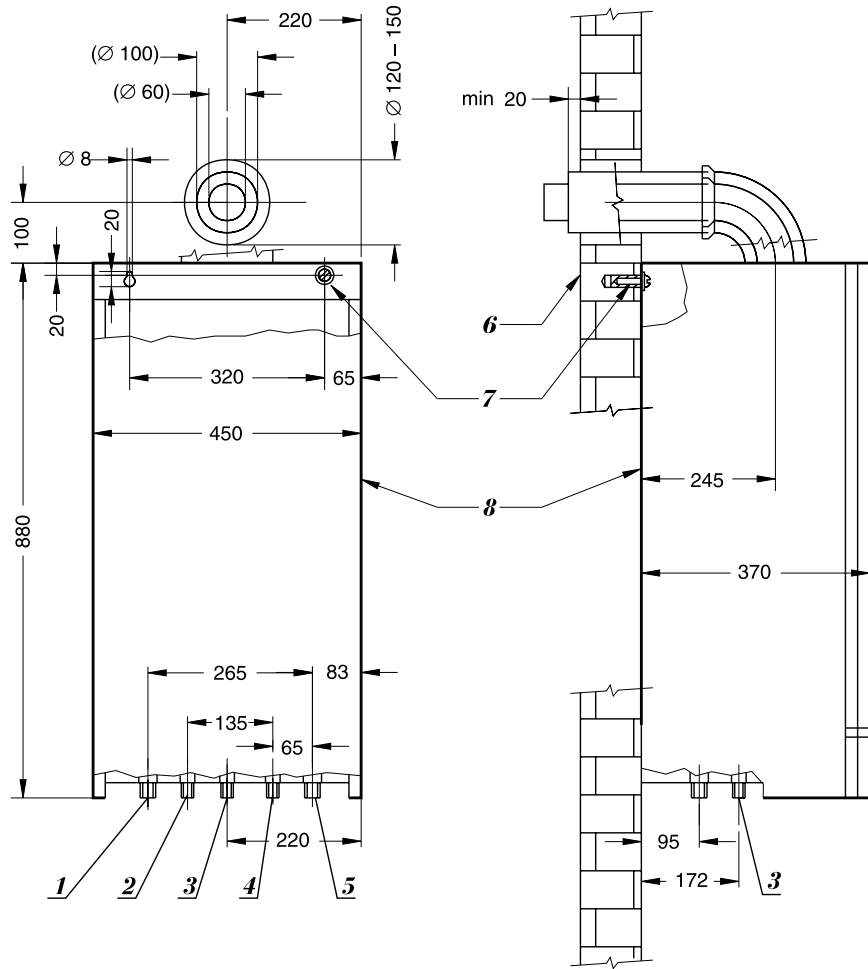
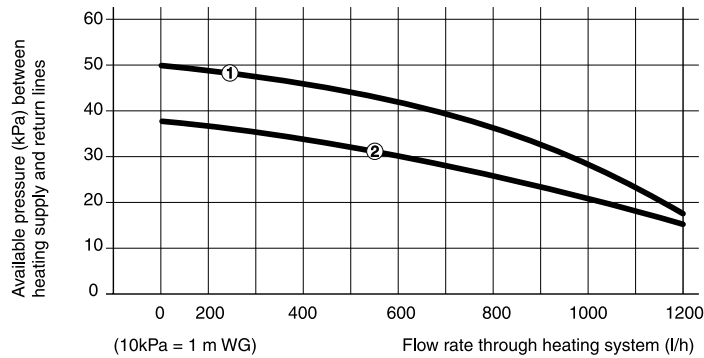

Diagram 2

- | | |
|--|--|
| 1 – Heating flow (pipe diameter 22 mm) | 5 – Heating return (pipe diameter 22 mm) |
| 2 – Hot water outlet (pipe diameter 15 mm) | 6 – Wall |
| 3 – Gas inlet (pipe diameter 22 mm) | 7 – Wall fixings |
| 4 – Cold water mains inlet (pipe diameter 15 mm) | 8 – Outer cover |



- ① Bypass fully shut
 ② Bypass open

Diagram 3

BOILER SCHEMATIC

PLEASE VISIT WWW.HEATINGSPPARES247.COM FOR FURTHER INFORMATION AND GENUINE PARTS & SPARES AT LOW PRICES

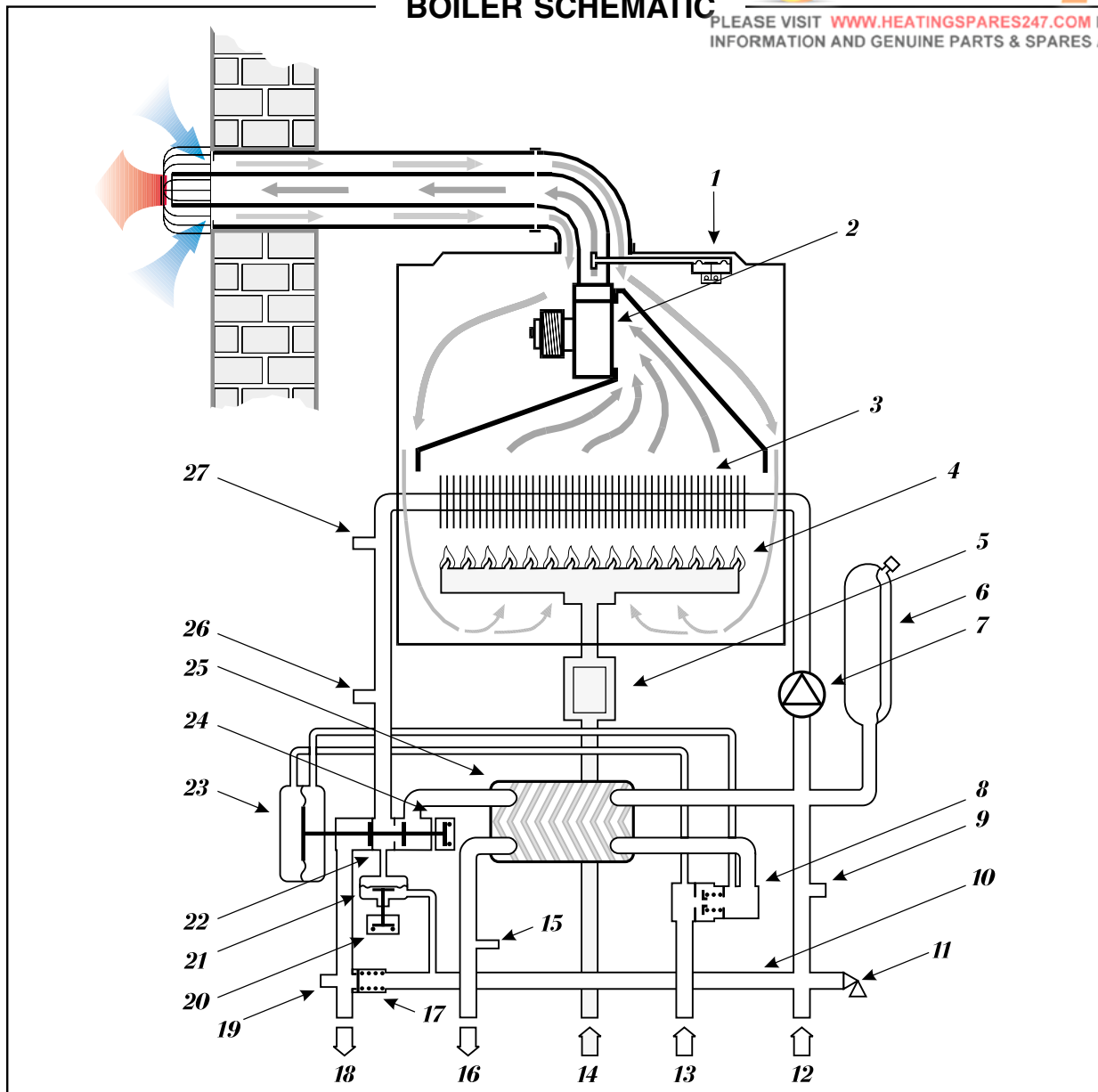

- | | |
|--------------------------------|------------------------------------|
| 1 – Air pressure switch | 15 – DHW thermistor |
| 2 – Fan | 16 – DHW outlet |
| 3 – Heat exchanger | 17 – Automatic by-pass |
| 4 – Burner | 18 – Heating flow |
| 5 – Gas valve | 19 – Drain |
| 6 – Expansion vessel | 20 – Microswitch |
| 7 – Pump | 21 – Loss of water pressure switch |
| 8 – Water flow sensor | 22 – 3-way valve |
| 9 – Pressure gauge connection | 23 – Differential valve |
| 10 – By-pass pipe | 24 – Microswitch |
| 11 – Safety valve | 25 – Secondary heat exchanger |
| 12 – Heating return | 26 – CH temperature sensor |
| 13 – Domestic cold water inlet | 27 – High limit thermostat |
| 14 – Gas inlet | |

Diagram 4

Clearances

The boiler can be installed with the following clearances:

- 25 mm either side of the boiler
- 50 mm to the front of the boiler
- 300 mm below the boiler
- 200 mm above the boiler

The above clearances are minimum clearances, consideration must be given to allow adequate space for servicing.

The recommended servicing clearances are:

- 50 mm either side of the boiler
- 600 mm to the front of the boiler
- 300 mm below the boiler
- 200 mm above the boiler

Terminal position

The minimum acceptable spacings from the terminal to obstructions and ventilation openings are shown in diagram 5 below:

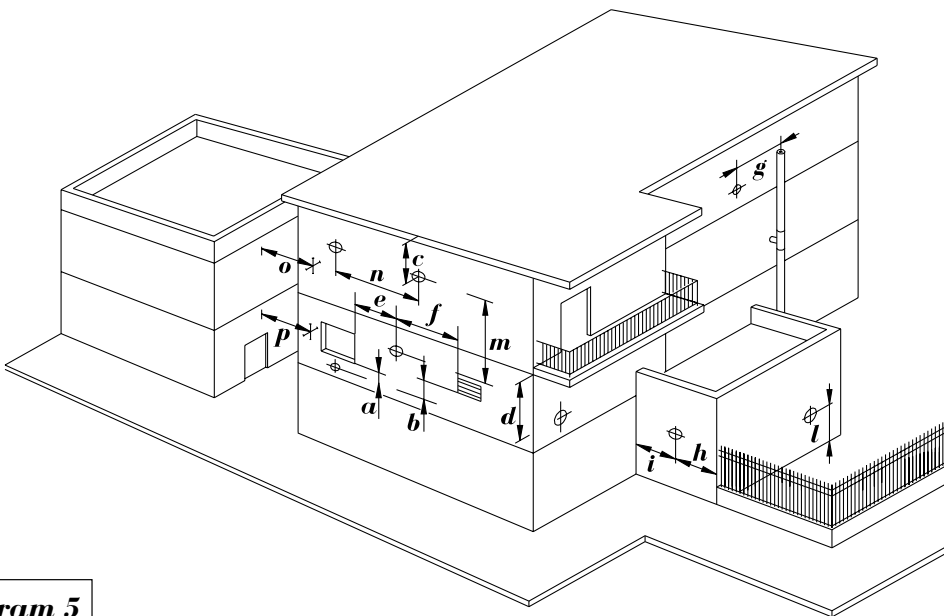

Diagram 5

Minimum dimensions (in mm) for the positioning of flue terminals

a	Under a window	300
b	Under an air vent	300
c	Under a gutter	75
d	Under a balcony	300
e	From an adjacent window	300
f	From an adjacent air vent	300
g	From vertical drain pipes or soil pipes	75
h	From an external corner of the building	300
i	From an internal corner of the building	300
l	From the ground or from another floor	300
m	Between two terminals vertically	1500
n	Between two terminals horizontally	300

Heating system design

The **Protherm 100 e** is compatible with any type of sealed system installation with radiators, fan convectors etc.

Pipe sectional areas shall be determined in accordance with normal practices, using the pump curve, refer to '**Technical Data**'. The distribution system shall be calculated in accordance with the output requirements of the actual system, not the maximum output of the boiler. However, provision shall be made to ensure sufficient flow so that the temperature difference between the flow and return pipes is less than or equal to 20 °C. The minimum flow is **500 l/h**.

The piping system shall be routed so as to avoid any air pockets and facilitate permanent venting of the installation. Bleed fittings shall be provided at every high point of the system and on all radiators.

The total volume of water permitted for the heating system depends, amongst other things, on the static head in the cold condition. The expansion vessel on the boiler is pressurised at 1 bar (corresponding to a static head of 10 m wg.) and allows a maximum system volume of 130 litres for an average temperature of 75 °C and a maximum service pressure of 3 bar. This pressure setting can be modified at commissioning stage if the static head differs.

Provision shall be made for a drain valve at the lowest point of the system.

Thermostatic radiator valves are permitted, however, not all radiators must be fitted with this type of valve and particularly where the room thermostat is fitted.

A suitable WRC approved filling loop must be fitted to enable correct filling of the system.

In all cases, it is **ESSENTIAL** that the system be thoroughly flushed prior to installing the new boiler.

Domestic hot water system design

Copper tubing or plastic Hep2O may be used for the domestic hot water system. Unnecessary pressure losses should be avoided.

The domestic hot water supply pressure must be between 1 and 6 bar. If the pressure exceeds 6 bar, a pressure reducing valve must be fitted.

In known hard water areas, it is recommended that a suitable scale reducing device is fitted to the cold water supply to the boiler.

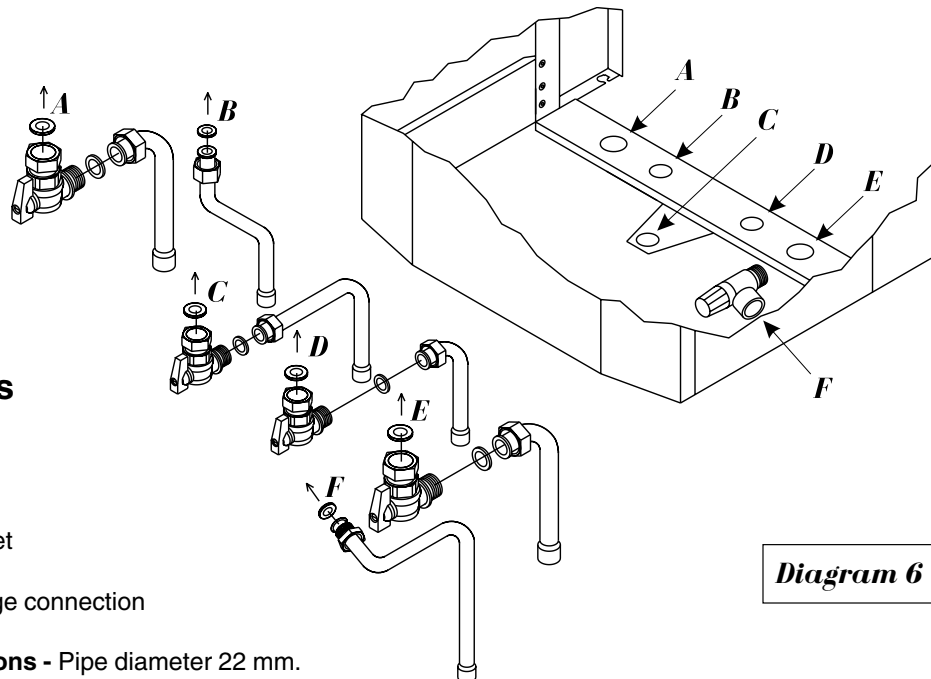

Boiler connections

- A Heating flow
- B Hot water outlet
- C Gas connection
- D Cold water mains inlet
- E Heating return
- F Safety valve discharge connection

Heating system connections - Pipe diameter 22 mm.

Hot water system connections - Pipe diameter 15 mm.

Gas connection - Pipe diameter 22 mm.

Safety valve discharge connection - Pipe diameter 22 mm.

Note: White color washers belong to hot water system connections.

Diagram 6

Safety valve discharge

WARNING: It must not discharge above an entrance or window or any type of public access area. Connect the safety valve discharge pipe to the valve, the discharge must be extended using not less than 15 mm o.d. pipe, to discharge in a visible position outside the building, facing downward, preferably over a drain. The pipe must have a continuous fall and be routed to a position so that any discharge of water, possibly boiling or steam, cannot create any danger to persons, damage to property or external electrical components and wiring. Tighten all pipe connection joints.

Gas connection

The supply from the governed meter must be of adequate size to provide a constant inlet working pressure of 20 mbar (8 in wg). To avoid low pressure problems, it is recommended that the supply is taken to the boiler using 22 mm pipe as far as possible. On completion, the gas installation must be tested using the pressure drop method and purged in accordance with the current issue of BS6891.

Gas Safety (Installation and Use) Regulations.

In your interests and that of gas safety, it is the law that **ALL** gas appliances are installed and serviced by a competent person in accordance with the above regulations.

Statutory requirements

The installation of this boiler must be carried out by a competent person in accordance with the relevant requirements of the current issue of:

- The Gas Safety (Installation and Use) Regulations
- The Building Regulations
- The local water company Bylaws
- The Building Standards Regulations (Scotland)
- The Health and Safety at Work Act

Sheet metal parts

WARNING: When installing or servicing this boiler, care should be taken when handling the edges of sheet metal parts to avoid the possibility of personal injury.

Installing the boiler

Prior to installing the boiler, the system must be thoroughly flushed to eliminate any foreign bodies and contaminants such as filings, solder, particles, oil, grease etc.

Note: Solvent products could cause damage to the system.

BOILER INSTALLATION

To install the boiler, proceed as follows:

- Allowing sufficient clearances for servicing/repair, place the template on the wall (see diagram 7).
- Determine the position of the flue hole and drill hole for flue , preferably using a 120 mm core drill.
- Drill two **10 mm** holes for the wallplugs supplied.
- Screw fixing screws supplied into wallplugs, leave proud by approx. 10 mm.

Note: Boiler fixing holes are keyhole type slots at the top of the boiler to allow easy hanging of boiler.

- Remove template.
- Hang the boiler on the screws and tighten screws.

Pipework connections

- Remove plastic caps from boiler connections.
- Connect the central heating pipework connections and isolating cocks as shown on diagram 6.
- Connect the domestic cold water inlet connection and isolating cock.
- Connect the hot water outlet connection.
- Connect the safety valve discharge pipe.
- Finally, connect the gas connection and isolating cock.

Note:

Remove the plastic caps from the boiler connections prior to connecting boiler to the pipework.

BOILER TEMPLATE

PLEASE VISIT WWW.HEATINGSAPARES247.COM FOR FURTHER INFORMATION AND GENUINE PARTS & SPARES AT LOW PRICES

Boiler connections

- A Heating flow
- B Hot water outlet
- C Gas connection
- D Cold water mains inlet
- E Heating return
- F Safety valve discharge connection

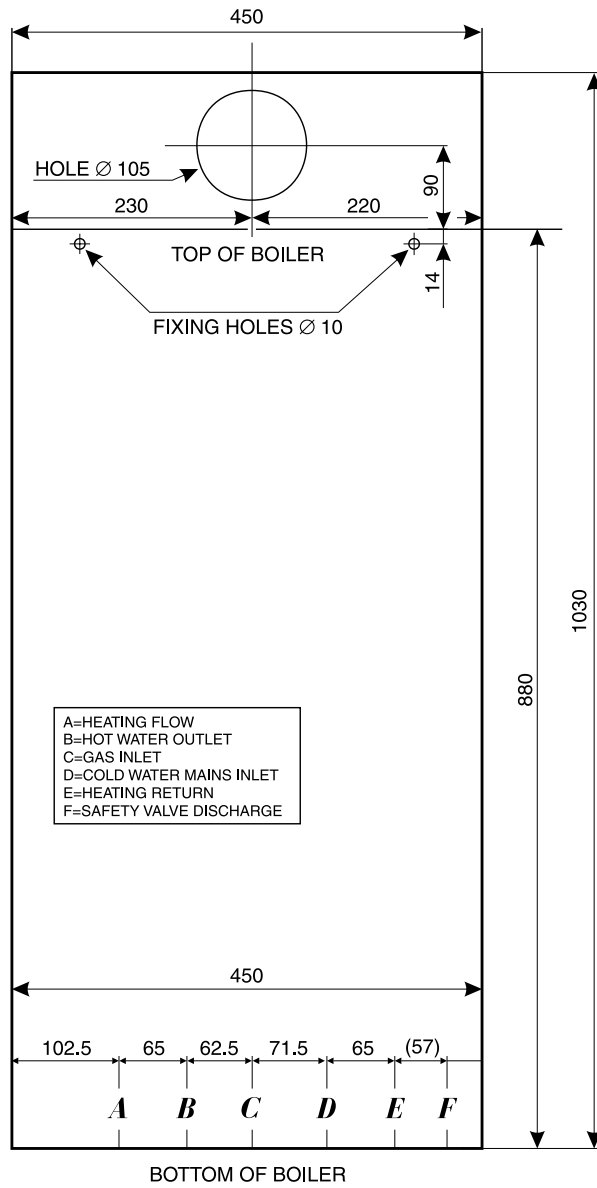

Diagram 7

Horizontal flue installation

- A Air inlet pipe
- B Terminal
- C Seal and clamp
- D Elbow
- E Gasket
- F Screws
- G External rubber sealing collar
- I Internal plastic collar
- J 'O' rings
- K Spacer (see diagram 9)

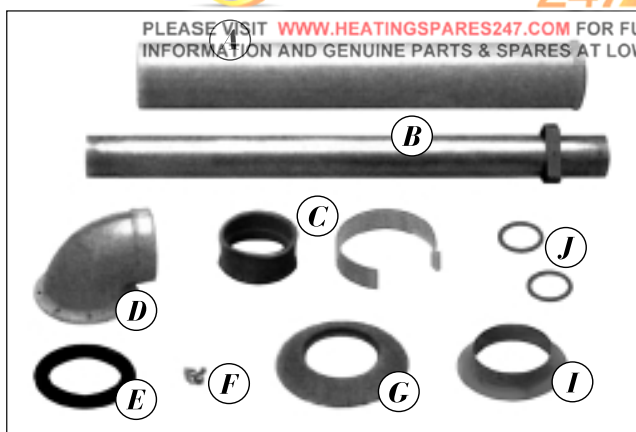

Diagram 8

- Fit gasket (E) onto underside of flue elbow (D).
- Carefully insert 'O' ring (J) into upper and lower parts of inner elbow.
- Place spacer (K) (supplied with boiler) onto top of boiler.
- Fit elbow onto spacer ensuring elbow inner connection locates correctly onto fan outlet.
- Fit external rubber sealing collar (G) onto air inlet pipe (A).
- Fit flue through hole in wall and pull up so that external collar (G) is flush against outside wall.
- Fit seal and clamp (C) to flue and assemble into elbow (D) making sure that both inner and outer pipes are sealed properly.

Note: Maximum horizontal length with no bends is 3 m.

- Tighten up clamp using screws provided.

Note: Should it be necessary to cut the flue, always cut equal amounts from both inner and outer pipes.

Always cut the end furthest from the terminal.

For each 90° flue bend fitted, reduce overall flue length by 1 m.

For each 45° flue bend fitted, reduce overall flue length by 1/2 m.

Horizontal flue kit	85090
Flue extension kit	85091
90° bend kit	85092
45° bend kit	85093

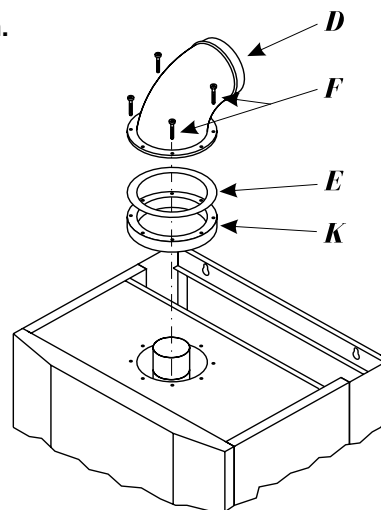
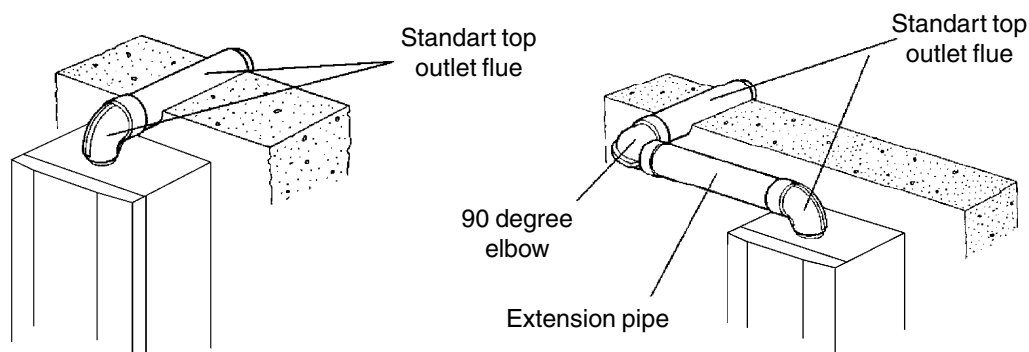

Diagram 9



Vertical flue installation

- Fit gasket (**E**) onto underside of vertical adaptor (**O**).
- Carefully insert 'O' ring (**J**) into vertical adaptor inner spigot.
- Place spacer (**K**) on the top of boiler.
- Fit vertical adaptor (**O**) onto spacer (**K**) ensuring adaptor inner connection locates correctly onto fan outlet.
- For flat roof installation, fit flat roof flashing collar (part no. 85107)
- Fit extension pipes (**M**) as required.
- Fit the terminal (**L**) onto roof ensuring flashing makes a watertight joint.
- For pitch roof installation, fit pitch roof flashing (part no. 85105).
- Fit flue terminal (**L**) onto roof ensuring flashing makes a watertight joint.

Note: Maximum vertical height with no bends is 5 m.
 Should it be necessary to cut the flue, always cut equal amounts from both inner and outer pipes.
 Connect condensate trap (supplied) to vertical flue adaptor when flue length exceeds 3 m.
 Connect 15 mm plastic pipe (not supplied).

For each 90° flue bend fitted, reduce overall flue height by 1 m.
For each 45° flue bend fitted, reduce overall flue height by 1/2 m.

Vertical flue terminal (black)	85103
Vertical flue terminal (brick)	85104
Pitched roof flashing	85105
Flat roof flashing	85107
Flue extension pipe	85099
90° bend kit	85101
45° bend kit	85102

Diagram 10

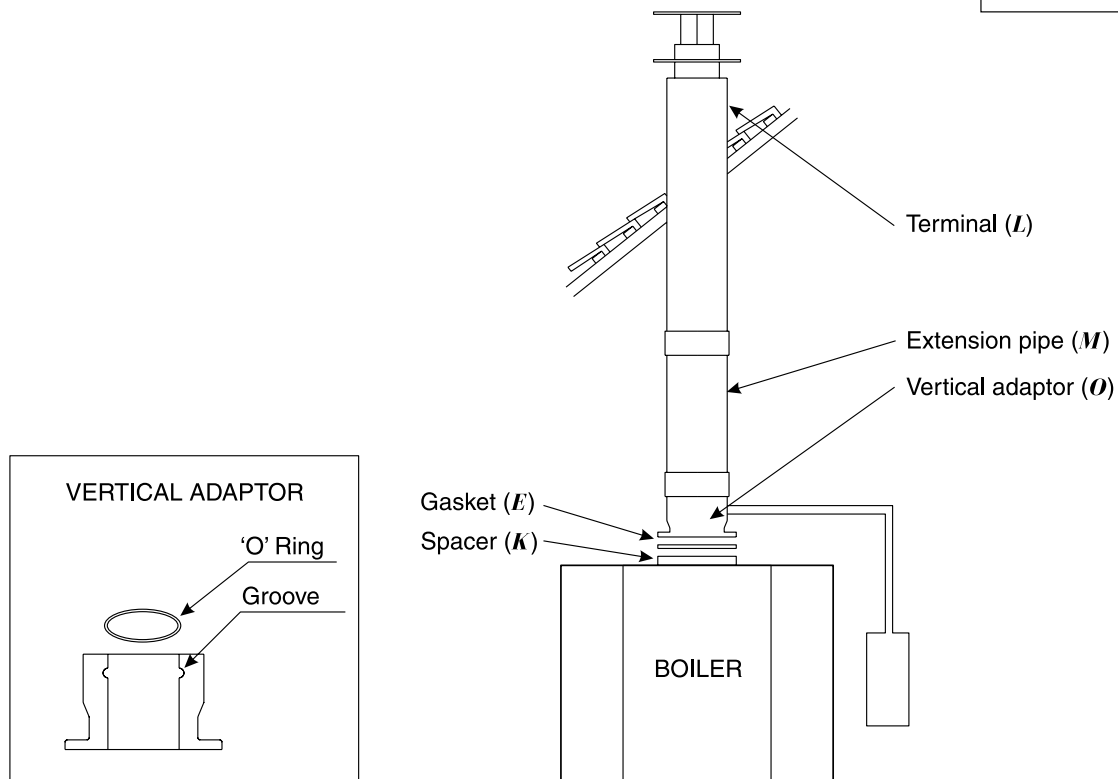

FLUE CONFIGURATIONS

PLEASE VISIT WWW.HEATINGSAPARES247.COM FOR FURTHER INFORMATION AND GENUINE PARTS & SPARES AT LOW PRICES

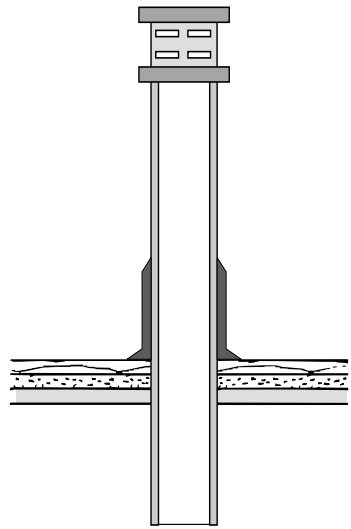
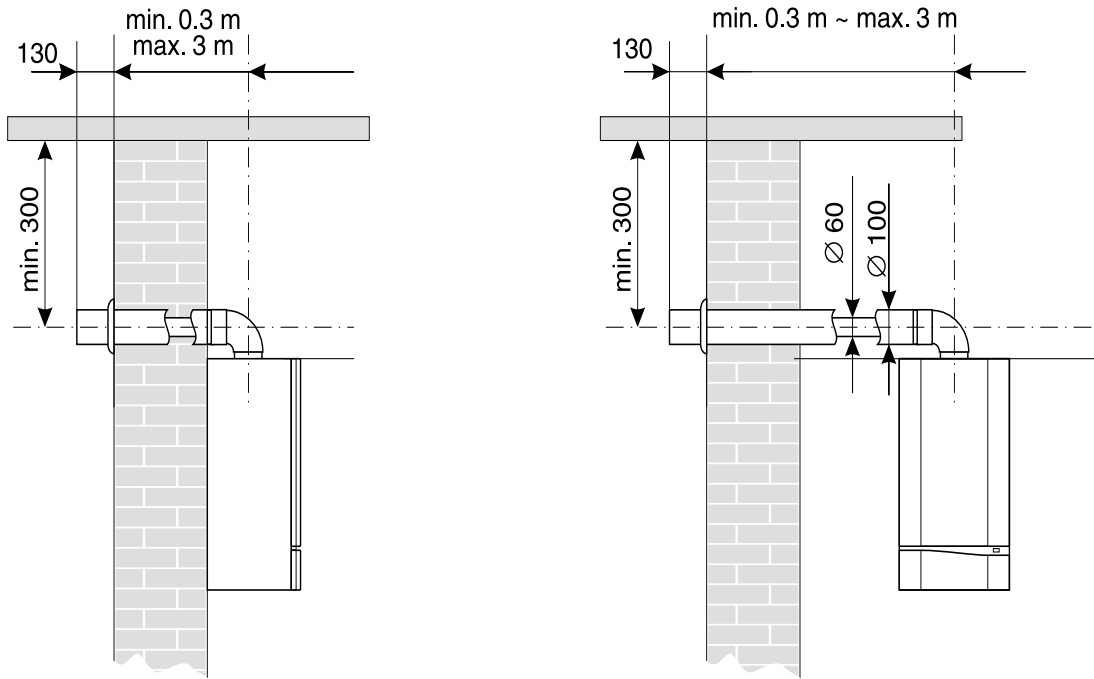

Flat roof which would normally require a black terminal

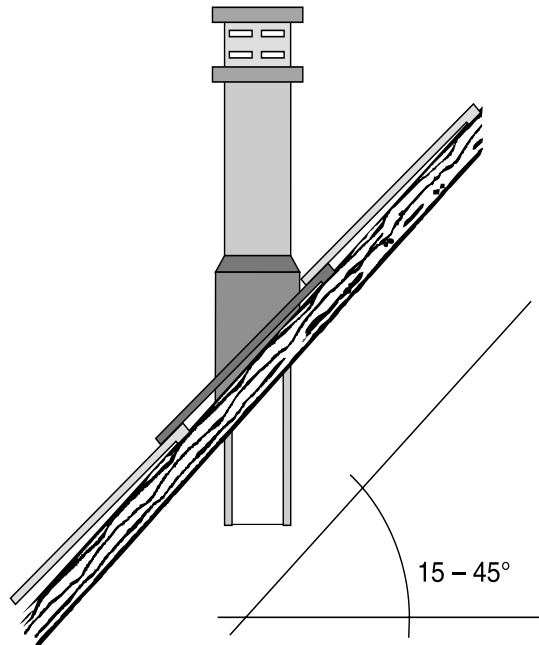

Pitch roof which would normally require a brick terminal

Diagram 11

ELECTRICAL CONNECTION

Warning: This boiler must be earthed.

All system components must be of an approved type.

Connection of the whole electrical system and any heating system controls to the electrical supply must be through a common isolator.

Isolation should preferably be by a double pole switched fuse spur box having a minimum contact separation of 3 mm on each pole. The fused spur box should be readily accessible and preferably adjacent to the boiler. It should be identified as to its use.

A fused three pin plug and shuttered socket outlet may be used instead of the fused spur box, provided that:

- They are not used in a room containing a bath or shower.
- Both the plug and socket comply with the current issue of BS1363.

The mains electrical supply must be maintained at all times in order to provide domestic hot water and frost protection.

It is recommended that a room thermostat is fitted.

Thermostatic radiator valves may be installed in addition to the room thermostat.

Note: For further information, see The Building Regulations 1991 - Conservation of fuel and power - 1995 edition - Appendix G, table 4b.

DO NOT INTERRUPT THE MAINS SUPPLY TO THE BOILER WITH A TIME SWITCH OR PROGRAMMER.

The **Protherm 100 e** is delivered with 1metre mains supply lead ready connected.

External controls

The boiler will work for heating **AS DELIVERED** without a room thermostat fitted provided the two wires on the integral external controls connection **REMAIN LINKED TOGETHER** (as supplied).

If a room thermostat is required, it must be connected as shown below and the link must be removed.

ANY ROOM THERMOSTAT USED MUST BE OF THE VOLTAGE FREE TYPE.

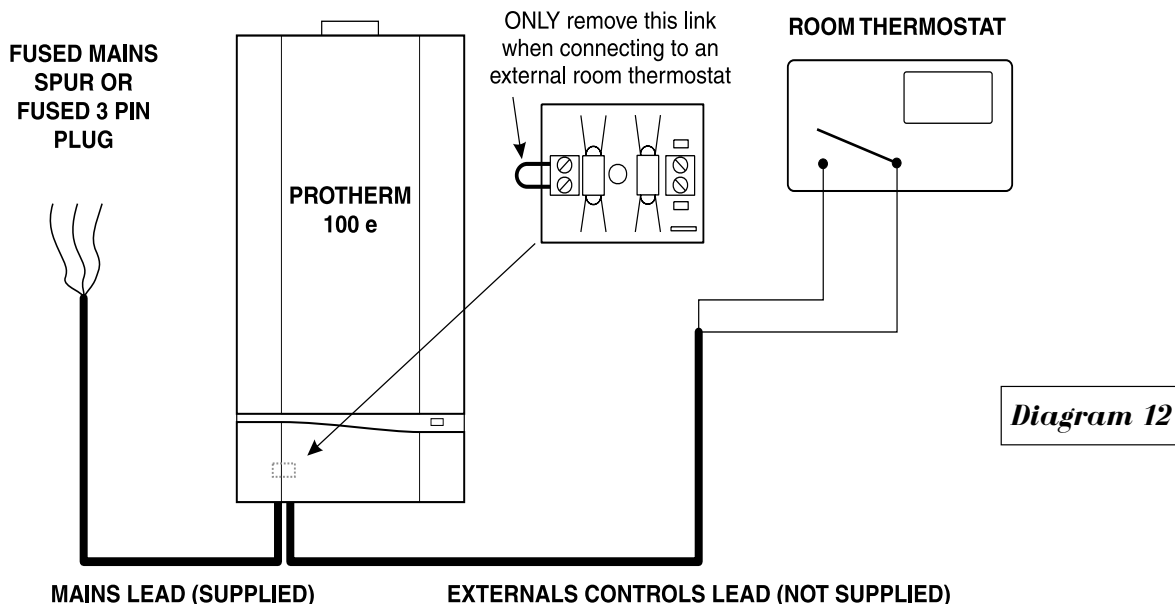

WARNING: ON NO ACCOUNT MUST ANY ELECTRICAL VOLTAGE BE APPLIED TO EITHER OF THE TERMINALS OF THE EXTERNAL CONTROLS CONNECTION

WARNING: This boiler must be wired in accordance with these instructions. Any fault arising from incorrect wiring cannot be put right under the terms of the guarantee.

COMMISSIONING

The commissioning and first firing of the boiler must only be carried out by a competent person.

To gain access to the inside of the boiler undo screws securing front panel at upper corners, remove front panel by pulling forwards and off. Disconnect earth wire from front panel.

Gas installation

It is recommended that any air is purged from the supply at the gas inlet test point on the gas valve, see diagram 13.

- 1 - Inlet test point
- 2 - Outlet test point

Filling the system

- Open isolating valves (**A**, **E** and **D**) see diagram 6 and cap on automatic air vent on top of pump, see diagram 19.
- Fill system by opening system filling loop until a pressure of between 1 and 2 bar is shown on the boiler pressure gauge.
- Bleed each radiator until a continuous jet of water is obtained.
- Do not close automatic air vent cap.
- Open various hot water taps to bleed hot water circuit.
- Make sure that pressure gauge reads between 1 and 2 bar. Re-pressure as necessary.

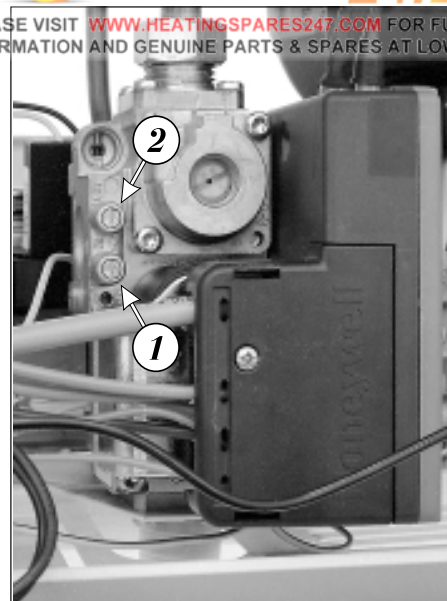

Diagram 13

Important:

When venting air from boiler, do not touch the schrader valve on the expansion vessel, it is NOT a vent.

Starting the boiler

Before starting the boiler check that:

- The gas meter tap is open.
- The boiler gas service cock is open.
- The water isolating cocks are open.
- The boiler is connected to the electrical supply.

First starting up

- Set boiler to run in central heating as described in '**Users Instructions**'.
- Set heating temperature control to maximum temperature and check that any external controls, if fitted, are calling for heat.
- Allow the temperature to rise to the maximum value, with all radiator valves open. Air contained in the water of central heating system will be automatically released through the automatic air vent. Air trapped at the highest point of the system must be released by bleeding the radiators. On reaching maximum temperature, the boiler should be turned off and the system drained as rapidly as possible whilst still hot.
- Refill system to a pressure of 1 bar and vent as before.
- Restart boiler and operate until a maximum temperature is reached. Shut down boiler and vent air from heating system. If necessary, top up heating system and make sure that a pressure of 1 bar is indicated on the pressure gauge when system is COLD.

Gas pressures

- Shut down boiler.
- Undo screw on gas inlet test point '1' on gas valve, see diagram 13.
- Connect a suitable pressure gauge.
- Start boiler as described in '**Users Instructions**'.
- Check that there is a constant pressure of 20 mbar. If the pressure is insufficient, it is necessary to check the gas supply/pipework and correct any fault.
- Shut down boiler.
- Remove pressure gauge, tighten up test point screw and check for gas soundness.

Setting the central heating output

The central heating output must be set in accordance with the system requirements. To adjust the burner pressure, proceed as follows, referring to the tables listed in 'Technical Data':

Gain access to the PCB as follows:

- Unclip the two plastic clips securing the lower control panel to the boiler side panels and hinge down.
- Unscrew and remove screws securing plastic PCB cover to rear of lower control panel and remove cover.
- Set the 'summer/winter' switch to the 'winter'  position
- Light the burner and check the gas pressure at pressure test point '2', see diagram 13
- Adjust the pressure using potentiometer TR1 on the PCB, see diagram 14.

- Note:** Do not adjust any of the other potentiometers.
- Refit PCB cover.

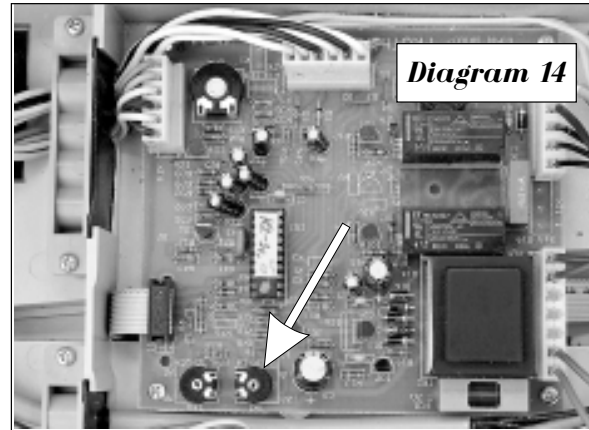

Safety devices

Air flow rate safety device

If an obstruction, even partial, of the flue occurs, the built in safety system of the boiler will turn the boiler OFF. The boiler will be ready to operate when the fault has been cleared.

In case of power supply failure

The boiler no longer operates. As soon as power is restored, the boiler will be automatically restarted. If the boiler does not restart, the overheat device may need resetting.

Overheat safety

In the event of overheating, the overheat safety device causes safety shutdown of the boiler. The digital display will show error code F1. To reset, press the reset button on the safety device, (a), see diagram 23.

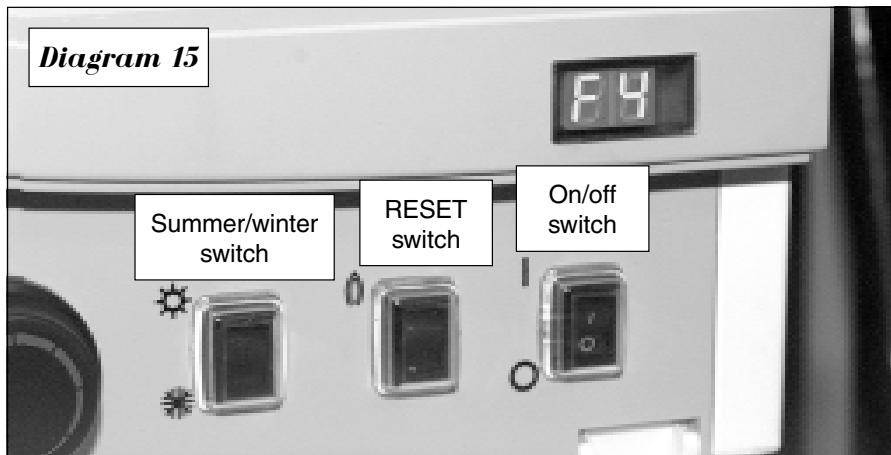

Important notice

A central heating system cannot operate satisfactorily unless it is properly filled with water and unless the air initially contained in the pipe-work system has been properly bled off. If these conditions are not satisfied, air noise will occur within the system and the boiler may fail to operate.

To reset the boiler (other than for overheating) use the reset button on the fascia, see diagram 15.

The **Protherm 100 e** boiler has a built-in frost protection device that protects the boiler during freezing conditions. Should the temperature within the central heating circuit of the boiler fall below 10 °C, the pump will switch on providing the electrical supply has been left connected. If the temperature falls below 8 °C, then the burner will operate until the water temperature increases to 25 °C. Should the electrical supply have been disconnected and the boiler/system has frozen, the boiler will not start up until the boiler/system has been cleared.

SERVICING INSTRUCTIONS

PLEASE VISIT WWW.HEATINGSPPARES247.COM FOR FURTHER INFORMATION AND GENUINE PARTS & SPARES AT LOW PRICES

To ensure the continued efficient and safe operation of the boiler, it is recommended that it is checked and serviced at regular intervals. The frequency of servicing will depend upon the installation conditions and usage but, in general, once a year should be enough.

It is the law that any servicing is carried out by a competent person.

Routine cleaning and inspection

- Operate boiler and check for any faults that need to be put right.
- Isolate boiler from the gas and electrical supplies.
- On completion check all gas carrying parts for soundness with leak detection fluid.

Remove boiler casing as follows:

Outer casing

- Undo screws securing the casing at upper corners and remove outer casing by pulling forwards and off.
- Disconnect earth lead from outer casing.

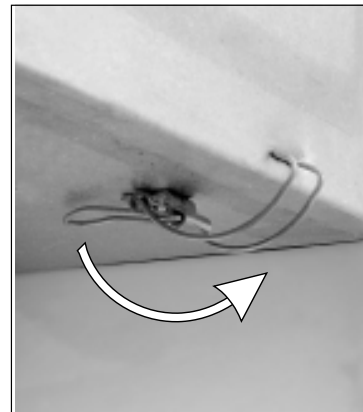

Sealed chamber

- Unclip two clips holding sealed chamber cover to boiler and lift it up and off, see diagram 16.

Diagram 16

Cleaning the burner

- Unscrew and remove 6 screws securing combustion chamber cover and remove cover.
- Disconnect flame sense electrode at burner.
- Disconnect ignition lead at gas valve module.
- Disconnect ignition earth lead.
- Undo nuts (A) securing gas supply pipe between burner and gas valve and remove pipe, see diagram 17.

Note: The washer between the burner and burner gas supply must be kept to use on reassembly.

- Unscrew 4 screws (B) securing burner to base of sealed chamber.
- Pull main burner up and forward out of boiler.
- Examine and clean burner as necessary.

Note: DO NOT use a wire or sharp instrument on the holes.

Heat exchanger

- Locate the heat exchanger inside the sealed chamber.
- Gain access to heat exchanger by removing fan and flue hood.
- Examine heat exchanger for any blockages or build up of deposits.
- Clean heat exchanger with soft brush or vacuum cleaner.

Reassembly of parts removed for servicing

All parts are replaced in reverse order to removal.

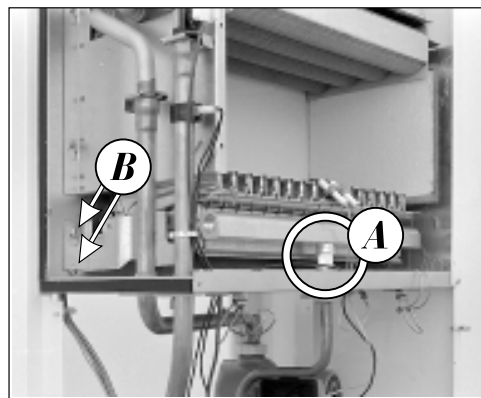

Diagram 17

Flue system

- Check externally to make sure that flue is not blocked
- Inspect flue system to make sure that all fittings are secure.

Operation of fan

- Switch on electrical supply and turn on gas.
- Set selector switch to 'Winter' ❄️ position.
- Remove sealed chamber cover.
- Light burner by operating external controls (if fitted) to call for heat.
- Check that fan operates when burner lights and stops when it goes out.

Replacement of parts

To gain access to the boiler components, proceed as follows:

- Isolate boiler from electrical supply.
- Remove outer case by grasping and gently pulling forwards.
- Supporting sealed chamber cover, unclip two clips securing cover to sealed chamber and lift off cover.
- Gently squeeze the two moulded plastic clips securing the lower front panel to the side panels; the lower front panel will now hinge down.

To replace fan

- Disconnect power supply and earth leads to fan.
- Supporting fan, unscrew and remove two screws securing fan to front of flue hood, see diagram 18.
- Gently ease fan forwards and out of boiler.
- Fit replacement fan in reverse order to removal making sure that mounting plate engages correctly onto flue hood

Important: Ensure that fan outlet is correctly fitted into flue elbow at top of boiler.



Diagram 18

To replace air pressure switch

- Locate air pressure switch in upper left hand corner of sealed chamber.
- Pull off clear plastic tube from base of switch.
- Remove electrical connections from switch.
- Unscrew and remove two screws securing switch to upper panel and remove switch – (or unclip air pressure switch from plastic holder – depends on type of switch used).
- Fit electrical connections to replacement switch as follows:
One to the microswitch connection marked 'NO 2'
One to the microswitch connection marked 'COM 3'
- Fit replacement switch in reverse order to removal.

Important: Refit clear plastic tube as follows:

Tube from tapping point of flue hood to switch point 'P 2-'

To replace pump

Drain down heating circuit only of boiler as follows:

- From below boiler, close isolating valves on flow and return connections to boiler.
- Open boiler drain valve on left hand side of hydraulic block.

Note: It is not necessary to drain down entire heating circuit to carry out this work.

- Undo screw **A** and remove pump electrical connection cover, see diagram 19.
- Unscrew electrical connections and disconnect pump cable.
- Supporting pump, unscrew pump connection nuts at top and rear of pump. Remove pump by lifting forward and out of boiler.
- Fit replacement pump in reverse order to removal.
- Open isolating valves on flow and return connections,
- Refill, vent and pressurise boiler. Check for leaks.



Diagram 19

To replace gas valve module

- Locate gas valve module attached to side of gas valve, see diagram 20.
- Unscrew screw (**a**) securing cover onto gas valve module.
- Remove cover and disconnect multi-plug from module.
- Disconnect ignition and flame sense leads from module and withdraw module from gas valve.
- Fit replacement module in reverse order to removal.
- Reconnect ignition and flame sense leads, the connections are uniquely sized to ensure correct replacement.
- Refit cover ensuring all sealing grommets are correctly located in module body.

To replace gas valve

- Ensure that gas supply is turned off at gas cock.
- Remove gas valve module as described previously.
- Undo nuts securing gas supply pipe between burner and gas valve and remove pipe, taking care not to lose sealing washers, see diagram 21.
- Remove gas inlet connection to boiler.
- Unscrew four screws securing gas inlet flange and gas valve to its mounting bracket.
- Remove gas valve by lifting upwards and out of boiler.
- Fit replacement gas valve in reverse order to removal.

To replace burner

- Remove burner as described in 'Cleaning the burner'.
- Fit replacement burner in reverse order to removal.

To replace domestic heat exchanger

- Drain down heating circuit of boiler as described previously.

Drain down hot water circuit of boiler as follows:

- From below boiler, close cold water inlet isolating valve.
- Open a hot tap to drain hot water circuit.
- Supporting the domestic heat exchanger, undo connections and turn heat exchanger until vertical.
- Manoeuvre heat exchanger up and forwards out of boiler, see diagram 22.
- Fit replacement heat exchanger in reverse order to removal, ensuring seals are correctly positioned in hydraulic block.
- Open isolating valves on flow and return connections, refill, vent and pressurise boiler. Check for leaks
- Open cold water isolating valve. Check for leaks.

To replace overheat thermostat

Important: Isolate boiler from electrical supply before this

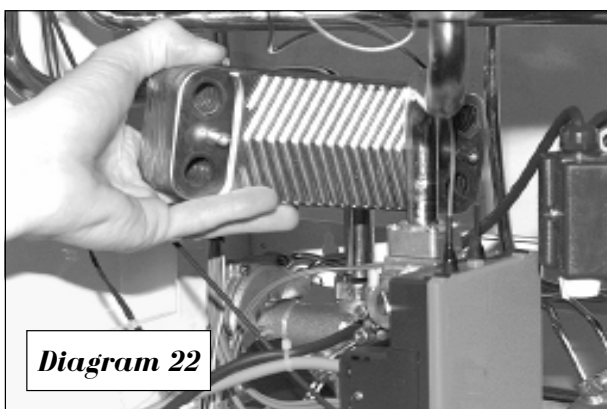

Diagram 22

To replace pressure gauge

- Drain boiler as described in 'To replace pump'.
- Unscrew pressure gauge capillary pipe nut on right hand side of hydraulic block.
- Unclip pressure gauge and pull out of lower front panel.
- Fit replacement pressure gauge in reverse order to removal.

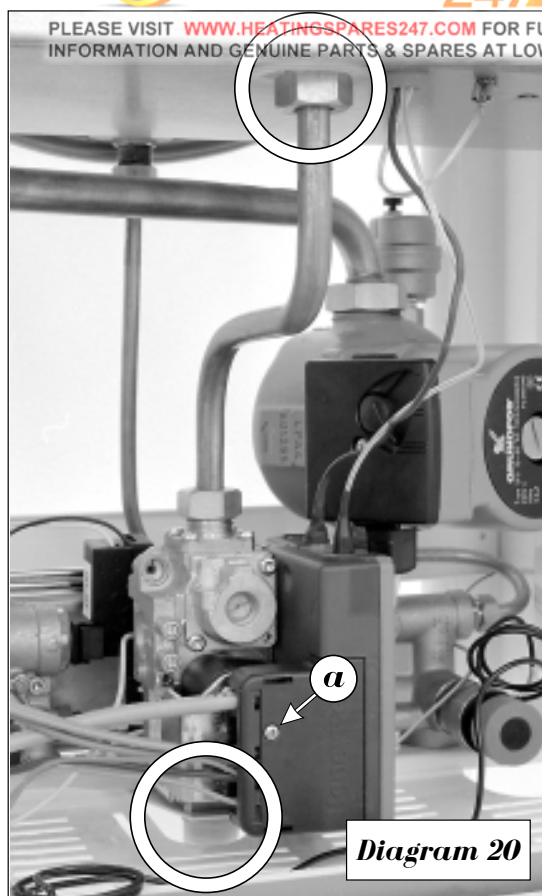
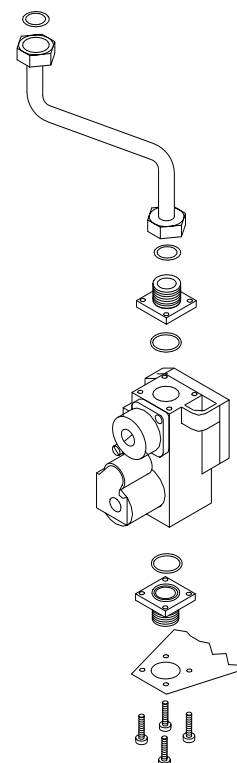

Diagram 20

Diagram 21



operation - connections to overheat thermostat are mains voltage.

- Locate overheat thermostat (a) to left hand side of sealed chamber above thermistor, see diagram 23.

To gain access to the thermostat, proceed as follows:

- Unscrew and remove two screws securing the lower grille on the left bottom of the boiler.
- Unscrew and remove two screws securing the left side cover.
- Remove the left side cover by pulling forward and aside.
- Unclip overheat thermostat from pipe.
- Pull off electrical connections from thermostat.
- Fit replacement overheat thermostat in reverse order to removal.

Note: No heat sink compound is required. The polarity of the connections is not important.

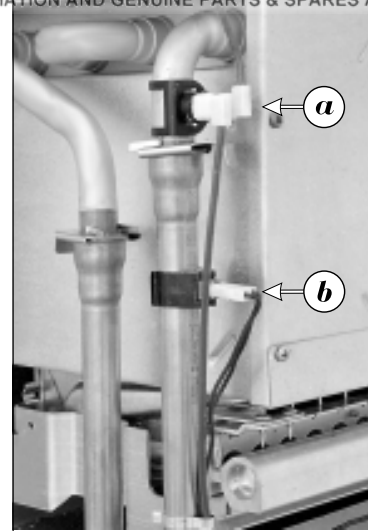

Diagram 23

To replace thermistor

- Locate thermistor (b) clipped onto flow pipe to left hand side of sealed chamber below overheat thermostat, see diagram 23.
- Unclip thermistor from pipe.
- Pull off electrical connections from thermistor.
- Fit replacement thermistor in reverse order to removal.

Note: No heat sink compound is required. The polarity of the connections is not important.

To replace printed circuit board (PCB)

- From behind lower control panel, unscrew and remove six screws securing PCB cover to panel.
- Pull off five molex type electrical plugs from PCB.
- Remove screws securing PCB to panel and lift out PCB.
- Fit replacement PCB in reverse order to removal, ensuring that domestic hot water and central heating temperature control spindles engage properly into PCB.
- Potentiometers on PCB and user controls need to be set to max. before fitting.

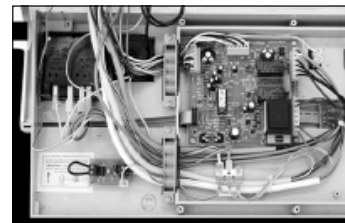

Diagram 24

To replace timeclock

- Remove PCB cover as described in 'To replace PCB'
- Disconnect clock electrical connections from PCB. Unclench and remove plastic clips securing timeclock to lower front panel.
- Remove timeclock from panel.
- Fit replacement timeclock in reverse order to removal.

To replace heat exchanger

- Drain down heating circuit of boiler only as described previously.
- Remove sealed and combustion chamber covers as described previously.
- Unscrew screws securing lower grille.
- Unscrew and remove screws securing left and right side covers.
- Remove both side covers by pulling forward and aside.
- Pull off spring clips securing heat exchanger pipes to heat exchanger.
- Manoeuvre heat exchanger pipes down to disengage from heat exchanger.
- Remove heat exchanger by sliding forward and out of boiler.
- Fit replacement heat exchanger in reverse order to removal.
- Open isolating valves on flow and return connections, refill, vent and pressurise boiler. Check for leaks.



Diagram 25

FAULT FINDING

PLEASE VISIT WWW.HEATINGSPPARES247.COM FOR FURTHER INFORMATION AND GENUINE PARTS & SPARES AT LOW PRICES

Before fault finding, make sure that:

- All gas cocks are open and there is an inlet gas pressure of 20 mbar.
- The heating system pressure is at least 1 bar.
- There is a permanent mains supply to the boiler.
- The fuse on the PCB is intact.
- All external controls are correctly wired and calling for heat.

WARNING: Always isolate the boiler from the electrical supply before carrying out any electrical replacement work. Always check for gas soundness after any service work.

Digital display shows:

- CHW temperature (no decimal point displayed)
- DHW temperature (decimal point lights)
- diagnostic error messages

As soon as the mains switch is on the display shows for a very short time the version of software used. It has no importance for boiler operation.

Diagnostic error messages

In the event of a fault, the following diagnostic error messages will be displayed.

Message	Fault	Action	Comments
F0	Flow rate sensor failure Loss of system water Air lock in boiler. Pump failure	Check sensor Refill system-check for leaks Bleed boiler and system Check the pump	Pump runs for one minute Pump runs for one minute Pump runs for one minute
F1	No flame detected Overheating	Check flame sense electrode Check ignition electrode Check ignition unit on gas valve Check fan operation Reset overheat thermostat	Boiler shuts down and pump runs if there is CH or DHW demand
F2	Central heating thermistor failure or CH water temperature below 3 °C	Check flow thermistor Check if system is not frozen	Boiler shuts down
F3	Heat exchanger blockage	Check main heat exchanger Check domestic heat exchanger	Boiler shuts down and pump runs
F4	Domestic hot water thermistor faulty	Check thermistor/leads	Domestic hot water is available but poor

Flashing decimal point when DHW temperature is displayed

This indicates that the domestic heat exchanger may be partially or fully blocked, the pump may be running too slowly or the central heating flow rate is too low.

Protherm 100 e - Conversion to LPG

- Isolate boiler from the gas and electrical supplies.
- Remove boiler casing and combustion chamber cover as described in Installation/Serviceing Instructions.
- Disconnect flame sense electrode.
- Disconnect ignition lead at gas valve module.
- Disconnect ignition earth lead.
- Undo nuts securing gas supply pipe between burner and gas valve and remove pipe.
- Unscrew two screws securing burner to base of sealed chamber.
- Pull main burner up and forward out of boiler.

Note: The washer between the burner and burner gas supply must be kept to use in reassembly.

- Fit new burner with marked injector diameter $\varnothing 0,73$ mm to the boiler in reverse order to removal.
- Readjust the gas valve.

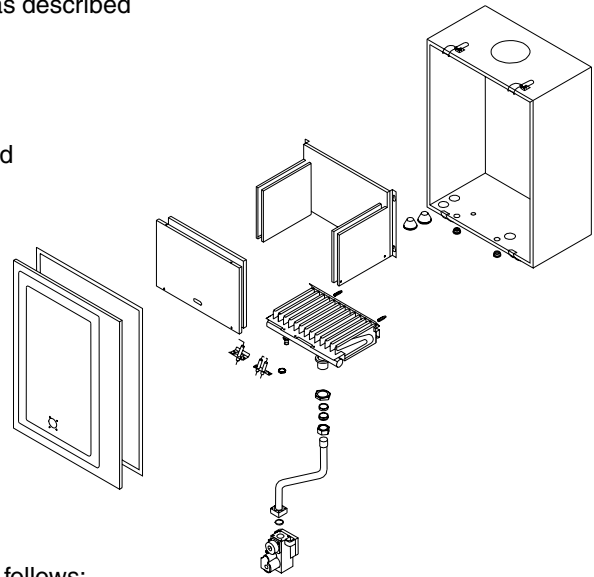

Gas Valve Adjustment

To adjust the minimum and maximum settings, proceed as follows:

- Gain access to the rear of the controls housing
- Remove the PCB cover
- Connect a manometer to the burner pressure test point (2) on the gas valve
- Turn potentiometer TR1, on the PCB, fully anti-clockwise
- Start boiler in Central Heating mode
- Adjust the gas valve minimum pressure **Pmin** using screw (C) on gas valve. Turn clockwise to increase, anti-clockwise to decrease.
- Turn potentiometer TR1, on the PCB, fully clockwise
- Start boiler in Domestic Hot Water mode
- Adjust gas valve maximum pressure **Pmax** using screw (B). Turn clockwise to increase, anti-clockwise to decrease

Note: It is first necessary to remove cover (A) to gain access to screw (B)

- If necessary, run boiler in Central Heating mode and adjust the range rating to suit the size of the heating system using potentiometer TR1. Refer to commissioning in Installation/Serviceing Instructions
- Disconnect manometer and check for gas soundness
- Replace all covers in reverse order to removal

	Inj. diam	Pmin	Pmax
G20 (20 mbar)	$\varnothing 1,20$ mm	2 mbar	15 mbar
G30 (30 mbar)	$\varnothing 0,73$ mm	4 mbar	29 mbar
G31 (37 mbar)	$\varnothing 0,73$ mm	4 mbar	36 mbar

- A - Cover
- B - Maximum adjustment screw
- C - Minimum adjustment screw
- 1 - Inlet pressure testpoint
- 2 - Burner pressure testpoint

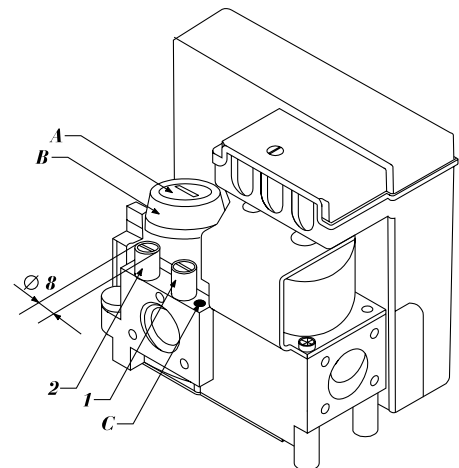

Combined gas armature Honeywell CVI-M

Wall hung combination boiler

PROTHERM 100 e

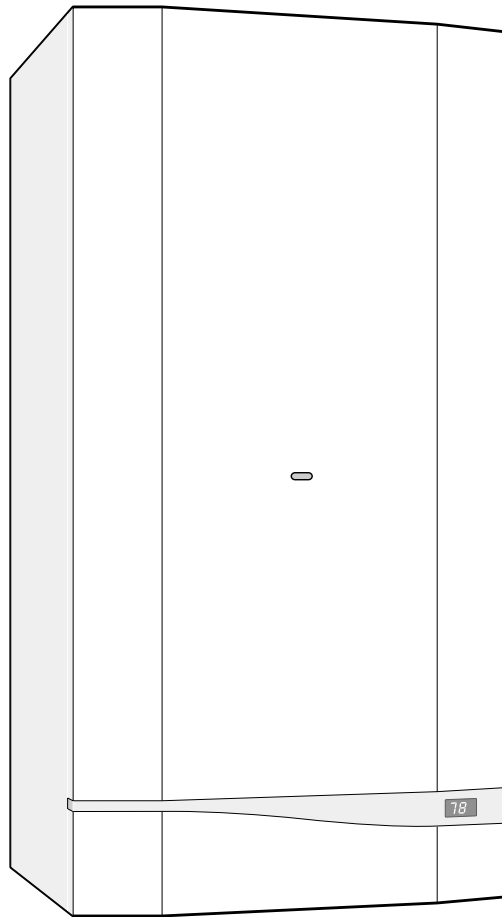

*USER, INSTALLATION, AND
SERVICING INSTRUCTIONS*

THIS IS A CAT II_{2H3+} APPLIANCE

Technical Advice & After Sales Service

HEATCALL

01773 828100